

karma

User manual

KP-10.3 Series

(KP-10.3S · KP-10.3 CPT)



CE UK
CA

A Better Wheelchair, A Better Fit

GENERAL WARNING

IMPORTANT

Do not attempt to use the powered wheelchair before a qualified person has explained to your satisfaction how to operate it without any risk to yourself or others.



WARNING

- Do not operate this powered wheelchair before first reading and understanding this owner's manual. If you are unable to understand the warnings, cautions, suggestions and technical instructions, please contact a dealer, healthcare professional or applicable personnel before attempting to use this power wheelchair -- otherwise, injury or damage may occur. If any procedures other than those described in this owner's manual, it must be performed by a qualified technician.

THE INFORMATION CONTAINED IN THIS DOCUMENT IS SUBJECT TO CHANGE WITHOUT NOTICE BY KARMA.



WARNING

- As a manufacturer of powered wheelchairs, KARMA endeavors to supply a wide variety of powered wheelchairs to meet the many needs of the user. However, the responsibility of final selection of the type of powered wheelchair to be used by an individual rests solely with the user and his/her healthcare professional capable of making such a selection.
- KARMA recommends that powered wheelchair users NOT be transported in vehicles of any kind while in a powered wheelchair. As of this date, the Department of Transportation (U.S.) has not approved any tie-down systems for transportation of a user while on a powered wheelchair in a moving vehicle of any type. It is the position of KARMA that users of powered wheelchairs should be transferred into appropriate seating in vehicles for transportation and make use of the restraints made available by the auto industry. KARMA cannot and does not recommend any powered wheelchair transportation systems. It is the responsibility of the Durable Medical Equipment (DME) Dealer, therapists and other healthcare professionals to determine if a seat positioning strap is required to ensure the safe operation of this equipment by the user. Serious injury can occur in the event of a fall from a powered wheelchair.

Operating Information

- Performance adjustments should ONLY be made by professionals of the healthcare field or persons fully conversant with this process and the driver's capabilities. Incorrect settings could cause injury to the driver or bystanders and damage to the powered wheelchair and surrounding property.
- To determine and establish your particular safety limits, practice bending, reaching, mounting and dismounting activities in several combinations in the presence of a qualified healthcare professional BEFORE attempting active use of the powered wheelchair.
- For individuals with balance problems, practice mounting and dismounting activities WITH AN ASSISTANT in the presence of a qualified healthcare professional.
- If so equipped, DO NOT operate the wheelchair without anti-tippers being installed. Anti-tippers MUST BE attached at all times.
- DO NOT attempt to reach objects if you have to move forward in the seat or pick them up from the floor by reaching down between your knees as this may cause loss of balance.
- DO NOT lean over the back of the chair to reach objects behind you as this may cause the powered wheelchair to tip over.
- DO NOT shift your weight or sitting position toward the direction you are reaching as the powered wheelchair may tip over.
- DO NOT use an escalator to move a powered wheelchair between floors. Serious bodily injury may occur.
- DO NOT operate in car lanes on roads, streets, highways, etc.
- DO NOT attempt to move up or down an incline with a water, ice or oil film.
- DO NOT attempt to ride over curbs or obstacles. Doing so may cause your powered wheelchair to turn over and cause bodily harm and/or damage to the powered wheelchair.
- DO NOT make sharp turns, in forward or reverse, at excessive speeds.
- DO NOT attempt to lift the powered wheelchair by its casings and seat.
- DO NOT attempt to lift the powered wheelchair by any detachable parts. Lifting by means of any detachable parts of a powered wheelchair may result in injury to the user or damage to the powered wheelchair. Please hold onto the frame when lifting your wheelchair.
- DO NOT operate the powered wheelchair until you have checked that the surroundings are clear and that the area is safe for travel.
- Please pay attention to the environment, and to keep away from the hazard of external flame. When the user is smoking, pay attention to safety and make sure to extinguish the fire when finished. Be alert to the environment when someone nearby is smoking or using a cigarette lighter, keep away from the hazard and use fire-proof cloth.
- DO NOT use parts, accessories or adapters other than those authorized by KARMA. Before attempting to sit in or exit the power wheelchair, turn the power OFF. This

will ensure that the power wheelchair will not drive. Turn the power OFF while the wheelchair is not in use. Otherwise, injury and/or damage to the wheelchair and surrounding property may occur.

- DO NOT connect any medical device (i.e., a ventilator, life support machine, et cetera) to the battery. This could cause unexpected failure of the device and the powered wheelchair. KARMA specifically disclaims responsibility to all personal injury and property damage that may occur during use which does not comply with applicable federal, state and local laws and ordinances.
- DO NOT stand on the footplates of the powered wheelchair.
- DO NOT use the wheelchair when the back is folded. This alters the centre of gravity and may cause the wheelchair to tip backwards. The back should only be folded for storage or transport of the wheelchair.
- DO NOT hang anything on the backjoints that could cause the backrest folding suddenly and may cause injury.
- DO NOT be towed by other vehicles (cars, motorcycles or bicycles, etc.). Only use freewheel mode on flat surfaces since your electromagnetic brakes are not engaged in this mode, without these brakes it will roll down a hill causing injury or damage. Never drive under the influence of alcohol or medication.
- DO NOT sit in the powered wheelchair within a moving vehicle unless it has been affixed the labels of hook mark.

WARNING

- **The wheelchair cannot be used as seats in any vehicles. That is, KARMA recommends that users are NOT transported in any vehicle while seated in the wheelchair. In the case of accident or a sudden stop, the user could be thrown from the wheelchair and get injured. The suggested solution is to transfer the user from the wheelchair into a normal seat of the vehicle and to securely stow the wheelchair in a separate compartment.**

RAMPS

- DO NOT climb, go up or down ramps or traverse slopes greater than the safe climbing angle for your model specified in section 10.
- When negotiating ramps, if the joystick is released while moving forward, the powered wheelchair will roll backwards approximately one foot before the brake engages. If the joystick is released while in reverse, the powered wheelchair will roll backwards approximately two and a half feet before the brake engages.
- Be sure to reduce your speed when driving on curved roads or making a turn; do not drive at full speed. Please drive at a slower speed so you have complete control of the wheelchair.

WARNING

- Do not drive the wheelchair on the ramp when the backrest is reclined with the backrest angle being 19°, or the wheelchair will flip over.

ELECTRICAL

- Check to ensure that all electrical connections are secure at all times.
- Grounding Instructions: DO NOT, under any circumstances, cut or remove the round grounding prong from any plug. Some devices are equipped with three-prong (grounding) plugs for protection against possible shock hazards.
- Where a two-prong wall receptacle is encountered, it is the personal responsibility and obligation of the customer to contact a qualified electrician and have the two-prong receptacle replaced with a properly grounded three-prong wall receptacle/outlet in accordance with the National Electrical Code and local laws.
- Do not use an extension cord when charging your batteries. A risk of fire and /or electric shock could be encountered.

BATTERIES

- The warranty and performance specifications contained in this manual are based on the use of deep cycle sealed lead acid batteries.
- KARMA strongly recommends their use as the power source for this unit. (Refer to Section 6)
- Carefully read the battery and charger information prior to installing, servicing or operating your wheelchair.
- DO NOT attempt to move an occupied powered wheelchair between floors using a stairway. (See Figure 1)
- Use an elevator to move an occupied powered wheelchair between floors. If moving a powered wheelchair between floors by means of a stairway, the occupant MUST be removed and transported independently of the powered wheelchair. Extreme caution is advised when it is necessary to move an UNOCCUPIED powered wheelchair up or down stairs.
- KARMA recommends disassembling the wheelchair and transporting the components independently up or down stairs. Make sure to use ONLY secure, non-detachable parts on each component for hand-hold supports.
- DO NOT attempt to lift a powered wheelchair by any removable (detachable) parts. Lifting by means of removable (detachable) parts may result in injury to the user or assistants or damage to the wheelchair.

RAIN TEST

- KARMA has tested its powered wheelchair in accordance with ISO 7176 Part 9 Rain Test. This test provides the end user or his/her attendant sufficient time to remove his/her powered wheelchair from a rainstorm and retain operation.

- DO NOT leave your powered wheelchair in a rain storm of any kind.
- DO NOT use your powered wheelchair in a shower or leave it in a damp bathroom while taking a shower.
- DO NOT leave your powered wheelchair in a damp area for any length of time. Direct exposure to rain or dampness could cause the powered wheelchair to malfunction electrically and mechanically and may cause the powered wheelchair to prematurely rust.

STAIRWAYS

- DO NOT attempt to move an occupied powered wheelchair between floors using a stairway. (See Figure 1)



(Figure 1)

- Use an elevator to move an occupied powered wheelchair between floors. If moving a powered wheelchair between floors by means of a stairway, the occupant MUST be removed and transported independently of the powered wheelchair. Extreme caution is advised when it is necessary to move an UNOCCUPIED powered wheelchair up or down stairs.
- KARMA recommends disassembling the wheelchair and transporting the components independently up or down stairs. Make sure to use ONLY secure, non-detachable parts on each component for hand-hold supports.
- DO NOT attempt to lift a powered wheelchair by any removable (detachable) parts. Lifting by means of removable (detachable) parts may result in injury to the user or assistants or damage to the wheelchair.

ESCALATORS? SORRY!

- DO NOT use an escalator to move a powered wheelchair between floors. Serious bodily injury and damage to the wheelchair may occur.

YOU AND YOUR KARMA SERVICE PROVIDER

- No tools are required for assembly. Your wheelchair should be assembled by your authorized KARMA dealer. Your authorized KARMA dealer is also your service provider. Unauthorized repairs, upgrades and add-ons will void your warranty.
- Anything wheelchair related that requires tools should be done by your authorized KARMA service provider. Your KARMA serviceprovider has the necessary service manual for your wheelchair.
- If you have any defective parts or lose any parts, please contact your dealer for repair and/or replacement. Please only use parts authorized by KARMA. Use of parts that are not authorized by KARMA will void your warranty.
- Part numbers are listed on our bill of materials (explosion drawings), which we give to our authorized dealers and service providers. Customers should order parts through their dealer as well as all repairs and scheduled maintenance.

- Customers should go to their dealership for all service needs to guarantee their warranty is not void. Always go to an authorized service provider. Unauthorized repairs will void your warranty. Procedures other than those described in this manual must be performed by a qualified technician. They also have the service manual with a complete list of maintenance required to keep your KARMA wheelchair in top performance.
- Check the warranty section of this manual to find out what KARMA guarantees and what maintenance service and parts that are not covered by the warranty.
- KARMA does not have an official list of service providers at this time. Please contact your dealer for service. If you cannot contact your dealer, please contact another authorized KARMA dealer for service. If all else fails, contact KARMA directly via our website or give us a call and we can refer you to your new service provider.

CLASSIFICATION & INTENDED USE

- KARMA's KP-10.3 Series are classified as a class A mobility product for indoor use. This wheelchair is suitable for users up to 120kg in weight. It also has an extremely durable aluminum alloy frame with tough accessory and does not suffer in dramatic extremes of temperature (neither the user nor the attendant need touch metal parts in normal use).
- Check with your local government as to legislation pertaining to mobility vehicles to assure your legal requirements to drive on public roads have been met, i.e. a pelvic belt, lighting, registration or licensing.

CE MARKING

- This powered wheelchair complies with the requirements of the Medical Devices Directive 93/42/EEC.



CAUTION

- When prescribing wheelchairs for use by full or partial amputees (above or below knee, single or double) or other conditions that affects the user's natural center of gravity and might cause the wheelchair to tip or the person on the wheelchair to fall off, we suggest contacting your therapist or dealer as well as attaching anti-tippers, pelvic belt, or other additional safety accessories.
- When using the wheelchair, ALWAYS follow the Highway Code or your local traffic regulations when outdoors and the guidelines written in this manual.

Declaration of conformity

EU Declaration of Conformity

We, with the information specified in the below,

Our information as the manufacturer:

Manufacturer's Name:	KARMA MEDICAL PRODUCTS CO., LTD
Manufacturer's Address:	NO. 2363, Sec. 2, University Rd., Min-Hsiung Shiang, Chia-Yi County, 62144, Taiwan
SRN (Single Registration Number):	TW-MF-000013206

Our authorized representative:

Name:	KARMA MOBILITY, S.L.
SRN (Single Registration Number):	ES-AR-000004852
Address:	C/ PERIODISTA FRANCISCO CARANTOÑA DUBERT, 23 Bajo 33209 GIJÓN – ASTURIAS, SPAIN
Contact Person:	Raquel Yuste
Contact Information:	(+34) 984 390 907

in accordance with

Regulation (EU) 2017/745 of the European Parliament and of the council Annex I, II, III, IV and IX

hereby declare that the medical device specified below:

Basic UDI-DI of Annex VI:	471987385KP-1L8
Device:	Electrically powered wheelchair
Trade Name or Mark:	Ergo Traveler / Ergo Nimble series (KP-10.3 series)
Model Number:	KP-10.3S, KP-10.3-CPT
Product Code according to EMDN:	Y122127
Product Code according to GMDN:	41637
Classification:	Rule 1 of Class I
UDI-DI:	04719873856619 04719873856626

is in conformity with the applicable requirements of the following documents:

Ref. No.	Title	Edition date
ISO 13485	Medical devices - Quality management systems - Requirements for regulatory purposes	2016
ISO 14971	Medical devices - Application of risk management to medical devices	2019
EN 12182	Assistive products for persons with disability - General requirements and test methods	2012
EN 12184	Electrically powered wheelchairs, scooters and their chargers - Requirements and test methods	2014
EN 62366	Medical devices - Application of usability engineering to medical devices	2015
EN 60601-1	Medical electrical equipment - Part 1: General requirements for basic safety and essential performance	2006
EN ISO 10993-1	Biological evaluation of medical devices - Part 1: Evaluation and testing within a risk management process	2009
EN ISO 10993-5	Biological evaluation of medical devices — Part 5: Tests for in vitro cytotoxicity	2009
EN ISO 15223-1	Medical devices - Symbols to be used with medical device labels, labelling and information to be supplied - Part 1: General requirements	2016
MEDDEV. 2.7/1 Rev. 4	CLINICAL EVALUATION: A GUIDE FOR MANUFACTURERS	2016
MEDDEV 2.12/1 Rev. 8	GUIDELINES ON A MEDICAL DEVICES VIGILANCE SYSTEM	2013

The information on this declaration has been stated on the sole responsibility of KARMA MEDICAL PRODUCTS CO., LTD.

We hereby declare that the device named above has been designed to comply with the relevant sections of the above referenced specifications. The device complies with all General Safety and Performance Requirements.

Date of issue: 23th August 2022

Place of issue: NO. 2363, Sec. 2, University Rd., Min-Hsiung Shiang, Chia-Yi County, 62144,
Taiwan

Richard Chang, CEO

UK Declaration of Conformity

We, with the information specified in the below,

Our information as the manufacturer:

Manufacturer's Name:	KARMA MEDICAL PRODUCTS CO., LTD
Manufacturer's Address:	NO. 2363, Sec. 2, University Rd., Min-Hsiung Shiang, Chia-Yi County, 62144, Taiwan
SRN (Single Registration Number):	TW-MF-000013206

Our UK responsible person:

Name:	Karma Mobility Ltd
MHRA Reference Number:	11480
Address:	Unit 6 Target Park, Shawbank Road, Redditch, B98 8YN England United Kingdom
Contact Person:	Mr Mark Duffield
Contact Information:	01527 520 468

in accordance with

UK MDR 2002 and Council Directive 93/42/EEC concerning medical devices in Annex I, II and VII hereby declare that the medical device specified below:

Basic UDI-DI of MDR(Annex VI):	471987385KP-1L8
Device:	Electrically powered wheelchair
Trade Name or Mark:	Ergo Traveler / Ergo Nimble series (KP-10.3 series)
Model Number:	KP-10.3S
Product Code according to EMDN:	Y122127
Product Code according to GMDN:	41637
Classification:	Rule 1 of Class 1
UDI-DI:	04719873856619 04719873856626

is in conformity with the applicable requirements of the following documents:

Ref. No.	Title	Edition date
EN ISO 13485	Medical devices - Quality management systems - Requirements for regulatory purposes	2016
EN ISO 14971	Medical devices - Application of risk management to medical devices	2019
EN 12182	Assistive products for persons with disability - General requirements and test methods	2012
EN 12184	Electrically powered wheelchairs, scooters and their chargers - Requirements and test methods	2014
EN 62366	Medical devices - Application of usability engineering to medical devices	2015
EN 60601-1	Medical electrical equipment - Part 1: General requirements for basic safety and essential performance	2006
EN ISO 10993-1	Biological evaluation of medical devices - Part 1: Evaluation and testing within a risk management process	2009
EN ISO 10993-5	Biological evaluation of medical devices — Part 5: Tests for in vitro cytotoxicity	2009
EN ISO 15223-1	Medical devices - Symbols to be used with medical device labels, labelling and information to be supplied - Part 1: General requirements	2016

The information on this declaration has been stated on the sole responsibility of KARMA MEDICAL PRODUCTS CO., LTD.

We hereby declare that the device named above has been designed to comply with the relevant sections of the above referenced specifications. The device complies with all Essential Requirements.

Date of issue: 23th August 2022

Place of issue: NO. 2363, Sec. 2, University Rd., Min-Hsiung Shiang, Chia-Yi County, 62144, Taiwan

Richard Chang, CEO

How to contact KARMA

KARMA

Head office

KARMA Medical

Address: NO.2363, Sec. 2, University Road, Minxiang Township,
Chiayi County 621015, Taiwan (R.O.C.)

Phone: +886 5 206 6688

Email: globalsales@karma.com.tw

Website: www.karmamedical.com

European representative

KARMA Mobility S.L.

Address: C/ Periodista Francisco Carantoña Dubert,
23 Bajo 33209 Gijón - Asturias (Spain)

Phone: +34 984 390 907

Email: karma@karmamobility.es

Website: www.karmamobility.es

UK representative

KARMA Mobility Ltd.

Address: Unit 6 Target Park, Shawbank Road, Reddtich,
B98 8YN England United Kingdom

Phone: +44 845 630 3436

Email: info@karmamobility.co.uk

Website: www.karmamobility.co.uk



Produced and published by KARMA Medical, Taiwan.

Technical changes and print errors are prohibited.



TABLE OF CONTENTS

1. PREFACE.....	1
2. SAFETY.....	2
2.1 BEFORE DRIVING	2
2.2 TRAFFIC RULES.....	2
2.3 PRACTICE DRIVING	2
2.4 NO PASSENGERS.....	3
2.5 NO HAULING HEAVY GOODS.....	3
2.6 RAIN	3
2.7 WHILE DRIVING	3
2.8 GENERAL WARNING	3
2.9 RAILROAD CROSSING.....	3
2.10 CIRCUMSTANCES TO AVOID	3
2.11 MOBILE PHONES AND OTHER ELECTRIC EQUIPMENT.....	3
2.12 RAMPS, INCLINES AND DROPS	4
2.13 MAXIMUM USER WEIGHT LIMIT	4
2.14 SERVICE LIFE.....	5
2.15 KP-10.3 SERIES LABELING.....	6
3. EMI/RFI.....	10
3.1 ELECTROMAGNETIC INTERFERENCE FROM RADIO WAVE SOURCES	10
3.2 THE SOURCES OF RADIATED EMI CAN BE BROADLY CLASSIFIED INTO THREE TYPES.....	11
3.3 POWERED VEHICLE ELECTROMAGNETIC INTERFERENCE (EMI).....	11
3.4 WARNINGS	12
4. PARTS.....	13
5. OPERATION.....	19
5.1 HOW TO OPERATE YOUR WHEELCHAIR.....	20
5.2 CONTROLLER CABLE FASTENING POSITION.....	21
5.3 DRIVING SPEED.....	22
5.4 FORWARD, REVERSE AND BRAKING	22
5.5 HORN BUTTON	23
5.6 BATTERY GAUGE.....	23
5.7 FREEWHEEL LEVERS.....	23
5.8 HOW TO ADJUST YOUR WHEELCHAIR, DISASSEMBLE AND ASSEMBLE YOUR WHEELCHAIR.....	24
5.9 ARMREST ADJUSTMENT FOR KP-10.3 SERIES.....	26

5.10 KP10.3 -CPT SEAT POSITION ADJUSTMENT.....	26
5.11 BACKREST ADJUSTMENT FOR KP-10.3 SERIES.....	27
5.12 DISASSEMBLING AND ASSEMBLING THE KP-10.3 SERIES.....	28
5.13 DISASSEMBLING AND ASSEMBLING KP-10.3-CPT.....	30
5.14 ANTI-TIPPERS.....	31
5.15 GETTING IN AND OUT.....	31
5.16 GETTING IN.....	32
5.17 GETTING OUT.....	32
6. BATTERIES AND CHARGER.....	32
6.1 BATTERY BOX OF 22 AH BATTERIES IN KP-10.3 SERIES.....	32
6.2 CHARGING THE BATTERIES.....	33
6.3 CHARGER.....	35
6.4 BATTERIES.....	35
7. INSPECTION AND MAINTENANCE.....	37
7.1 DAILY CHECK.....	37
7.2 REGULAR MAINTENANCE RECORD.....	37
7.3 TIRES.....	39
7.4 GENERAL MAINTENANCE.....	39
7.5 SUGGESTED MAINTENANCE PROCEDURES.....	39
7.6 KP-10.3 SERIES INSTRUCTIONS FOR LUBRICATION.....	40
7.7 TRANSPORTING AND STORING.....	40
8. OPTIONAL ACCESSORIES.....	41
9. TROUBLESHOOTING.....	42
10. SPECIFICATIONS.....	46
11. CLEANING & RECYCLING.....	48
11.1 CLEANING.....	48
11.2 POST-CONSUMER RECYCLING.....	49
12. WARRANTY.....	50
12.1 SERIAL NUMBER.....	50
12.2 CONTENTS AND DURATION OF WARRANTY.....	50
12.3 THE CLAIMS FROM THIS WARRANTY SHALL NOT ARISE FOR THE FOLLOWING REASONS.....	50
12.4 THE RESPONSIBILITIES OF THE USER.....	51
12.5 THE RESPONSIBILITIES OF THE DEALER.....	51
12.6 TRANSFER OF WARRANTY RIGHTS.....	52

1. PREFACE

- 1.1 Please carefully read this owner's manual before using the wheelchair. Improper use of the wheelchair could result in harm, injury or traffic accidents. Therefore, for safe and enjoyable use of the wheelchair, please read this owner's manual.
- 1.2 This owner's manual includes operation instructions for the aspects of the wheelchair, assembly instructions, and instructions on how to deal with possible accidents. This owner's manual is written for KARMA powered wheelchair(s): KP-10.3 Series.
- 1.3 The symbols used in this manual are explained below. Pay special attention to the parts marked with these symbols.

 WARNING	Improper use could lead the user to severe injury or death.
 CAUTION	Improper use could lead the user to severe injury and/or damage to your wheelchair.
 SUGGESTION	Follow these instructions to keep the wheelchair in good condition.

- 1.4 This manual includes the repair and maintenance chart as well as the Warranty. Please keep it in a safe place or with the wheelchair.
- 1.5 If someone else uses the wheelchair, make sure that you give him or her this owner's manual for his or her reference.
- 1.6 As designs change, some illustrations and pictures in this manual may not correspond to the vehicle that you purchased. We reserve the right to make design modifications without further notice.

2. SAFETY

2.1 Before Driving

2.1.1 The user must be familiar with the use and operation of this wheelchair before driving.

2.1.2 Therefore, please always keep these safety guidelines in mind.

WARNING

- **When prescribing wheelchairs for use by full or partial amputees (above or below knee, single or double) or other conditions that affects the user's natural center of gravity and might cause the wheelchair to tip or the person on the wheelchair to fall off, we suggest contacting your therapist or dealer as well as attaching anti-tippers, safety belt, or other additional safety accessories.**

2.2 Traffic Rules

2.2.1 Pedestrian traffic rules apply to this wheelchair. Please be safe.

2.2.2 Drive only on pedestrian areas such as the sidewalk. Never drive the wheelchair on the highway.

2.2.3 Be aware of other vehicles when crossing all roads.

2.2.4 Be extremely cautious when driving your wheelchair in heavy traffic or the shopping mall.

2.2.5 DO NOT drive your wheelchair when you feel tired or consume alcohol.

2.2.6 Please do not drive your wheelchair at night.

2.2.7 Please follow pedestrian traffic lights.

WARNING

- **When using the wheelchair, ALWAYS follow the Highway Code when outdoors and the guidelines written in this manual.**

2.3 Practice Driving

2.3.1 Before you are familiar with the operation of your wheelchair please practice in a wide and open area, like a park.

2.3.2 To avoid falling off your wheelchair please practice all kinds of driving motions, such as accelerating, stopping, turning, reversing and going up and down ramps.

2.3.3 Please set the speed to medium when you first start practicing.

2.3.4 Be safe. Make sure someone accompanies you in case you need assistance.

2.3.5 Be sure you are able to control and operate your wheelchair easily and confidently before you set the speed up.

2.4 No Passengers

KARMA wheelchair is limited to one driver. Do not carry passengers (including children) on your wheelchair.

2.5 No Hauling Heavy Goods

Do not use this wheelchair to carry or haul heavy goods. The maximum weight that can be carried, including goods, is stated beside "Max. User Weight" in section 10. SPECIFICATIONS.

2.6 Rain

This product is not guaranteed to be water resistant. Please do not drive in the rain, through puddles or spray water to clean this product. (See Figure 2.1)

2.7 While Driving

Please carry out daily inspections. Refer to section 7.1 DAILY CHECK

2.8 General Warning

2.8.1 Do not lean over the side of the wheelchair as such an action may cause you to lose balance and fall.

2.8.2 Use caution to assure your clothing doesn't get tangled with the wheels.

2.9 Railroad Crossing

2.9.1 Before crossing the tracks, please stop completely and look both ways.

2.9.2 Cross the tracks perpendicular to avoid your wheels getting stuck.

2.9.3 Do not drive at full speed over railroad tracks.

2.10 Circumstances to Avoid

2.10.1 Avoid roads with heavy traffic, mud, excessive gravel or bumps, snow and ice. These conditions may damage your wheelchair.

2.10.2 Avoid roads that are too narrow or by a canal/waterway without any fence/hedge.

2.10.3 Also avoid places where your wheels might get stuck, slip or not have traction.

2.10.4 Do not drive in a gale, at night or in rainy/snowy/foggy/misty weather. These conditions may cause your wheelchair to rust.(See Figure 2.2)

2.10.5 Do not drive in a S curve, do doughnuts or make sudden turns.

2.10.6 Do not take an escalator.

2.11 Mobile Phones and Other Electric Equipment

2.11.1 Do not use a mobile phone or other wireless communication devices while driving.
(See Section 3. EMI/RFI)

2.11.2 Do not charge the mobile phone or other electric devices from your wheelchair's batteries.

2.12 Ramps, Inclines and Drops

2.12.1 Do not drive onto a steep ramp. Refer to "Max. Climbing Ability" in section 10.

SPECIFICATIONS for your wheelchair's maximum climbing angle.

2.12.2 When climbing up to an inclined road, please set the speed higher than the medium speed and drive carefully. (See Figure 2.3)

2.12.3 When going down an inclined road, set the speed to "1" and never use reverse.

2.12.4 Do not drive on a road with many bumps and holes close to each other, such as potholes or washboard roads. (See Figure 2.4)

2.12.5 Do not make sudden turns when driving on gravel roads or ramps.

2.12.6 The maximum surmountable obstacle height is 5 cm for your wheelchair. Exceeding this obstacle height will damage your wheelchair and void your warranty. (See Figure 2.5)

2.12.7 When negotiating an obstacle slow down, put your seat into the full upright position and approach it head on (perpendicular).

2.12.8 Just before the obstacle, speed up until the entire wheelchair has conquered the obstacle. Negotiating an obstacle at an angle may cause your wheelchair to tip over. Don't do it!

2.12.9 When climbing down a curb, slow down just before you get to it and only speed up after the entire wheelchair has lowered to the road.

2.12.10 Again, descending obstacles should be done perpendicularly. (See Figure 2.6)

2.12.11 KARMA does not design wheelchairs to take jumps over or off obstacles. Doing so will void your warranty.



WARNING

- Do not set the wheelchair in freewheel mode when on an incline or decline.
- If you breakdown on railroad tracks, first, check for an oncoming train. If a train is coming, get out of its way immediately! If no train is coming, set to freewheel mode and push the wheelchair off the tracks.

2.13 Maximum User Weight Limit

2.13.1 Refer to "Max. User Weight" in section 10. SPECIFICATIONS.

2.13.2 Loads exceeding maximum capacity can damage your wheelchair and cause malfunctions yielding a safety hazard. The warranty does not cover damage caused by improper operation of the wheelchair.



(Figure 2-1)



(Figure 2-2)



(Figure 2-3)



(Figure 2-4)



(Figure 2-5)



(Figure 2-6)

2.14 Service life

The expected service life of the product is **five years**, presuming that the product is used daily in accordance with the safety operation instructions, inspection and maintenance instructions, and intended use, which described in this manual.

2.15 KP-10.3 Series Labeling

Please carefully read all the labeling on the wheelchair before driving it. Do not remove them. Protect them for future reference.

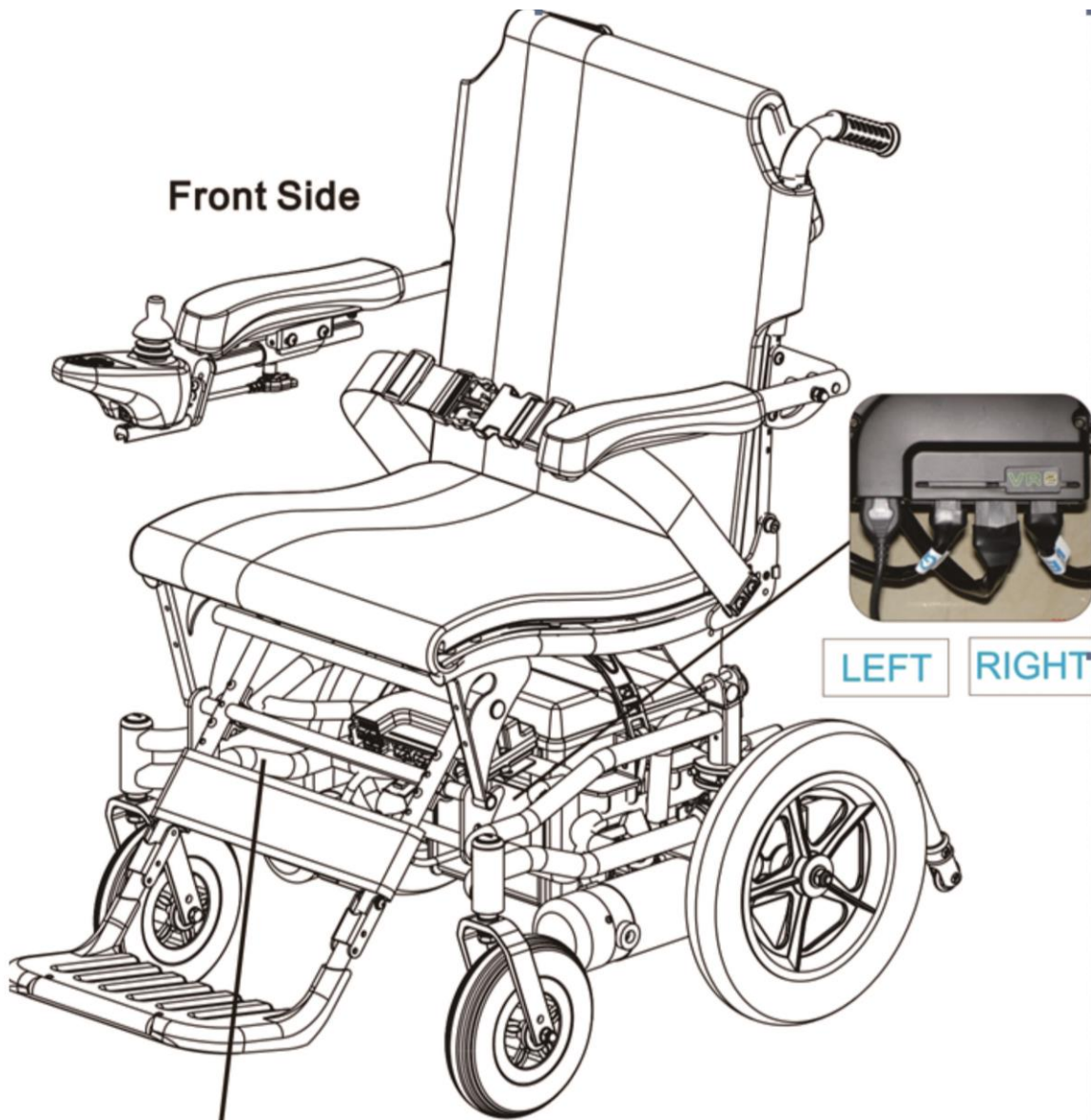

	Karma Medical Products Co., Ltd. 2363, Sec. 2 University Rd., Min-Hsiung, Chia-Yi 621, Taiwan		
TYPE	KP-10.3 CPT		
	v max. : 6 km/h		max. : 8°
	120 kg	SN	MD

	KARMA MOBILITY, S. L. C/ PERIODISTA FRANCISCO CARANTOÑA DUBERT, 23 Bajo 33209 GIJÓN - ASTURIAS (SPAIN)	
	KARMA MOBILITY LTD. UNIT 6 TARGET PARK, SHAWBANK ROAD, REDDITCH, B98 8YN ENGLAND UNITED KINGDOM	

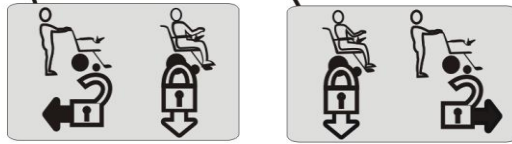
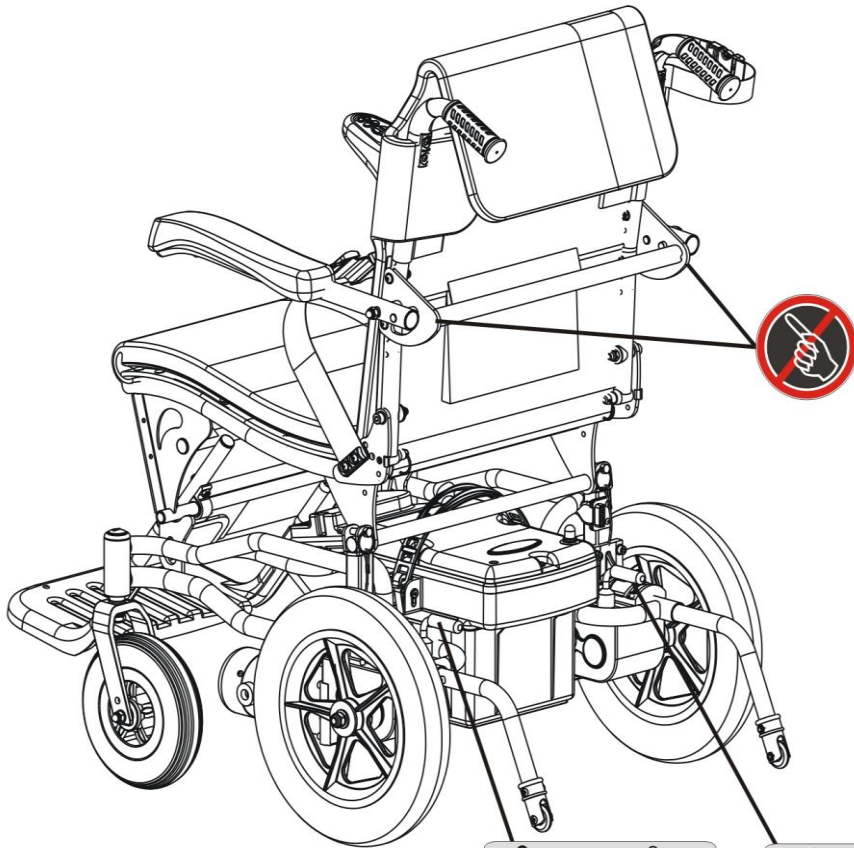

⚠
 If there are any problems or unusual situations with the battery or power system, please contact your KARMA wheelchair dealer for help. NEVER disassemble or repair the battery, otherwise, injury or damage may occur. This will negate the warranty.

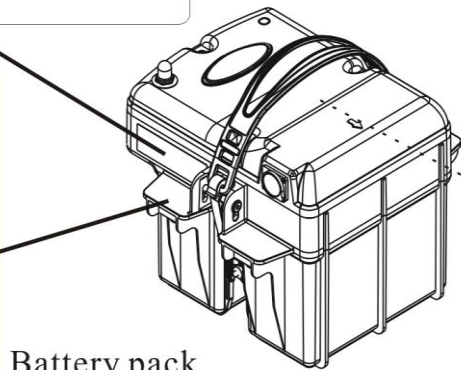

Battery pack

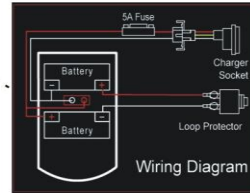

(inside)



EC	REP	KARMA MOBILITY, S. L. C/ PERIODISTA FRANCISCO CARANTOÑA DUBERT, 23 Bajo 33209 GIJÓN - ASTURIAS (SPAIN)	  
UK	REP	KARMA MOBILITY LTD. UNIT 6 TARGET PARK, SHAWBANK ROAD, REDDTICH, B98 8YN ENGLAND UNITED KINGDOM	
		KARMA MEDICAL PRODUCTS CO., LTD. NO. 2363, SEC. 2, UNIVERSITY RD., MIN-HSIUNG SHIANG, CHIA-YI HSIEN, TAIWAN R.O.C.	
 WARNING! USE ONLY ON STABLE SURFACES MAXIMUM USER WEIGHT 120kg (265 lbs)			

EC	REP	KARMA MOBILITY, S. L. C/ PERIODISTA FRANCISCO CARANTOÑA DUBERT, 23 Bajo 33209 GIJÓN - ASTURIAS (SPAIN)	
UK	REP	KARMA MOBILITY LTD. UNIT 6 TARGET PARK, SHAWBANK ROAD, REDDTICH, B98 8YN ENGLAND UNITED KINGDOM	

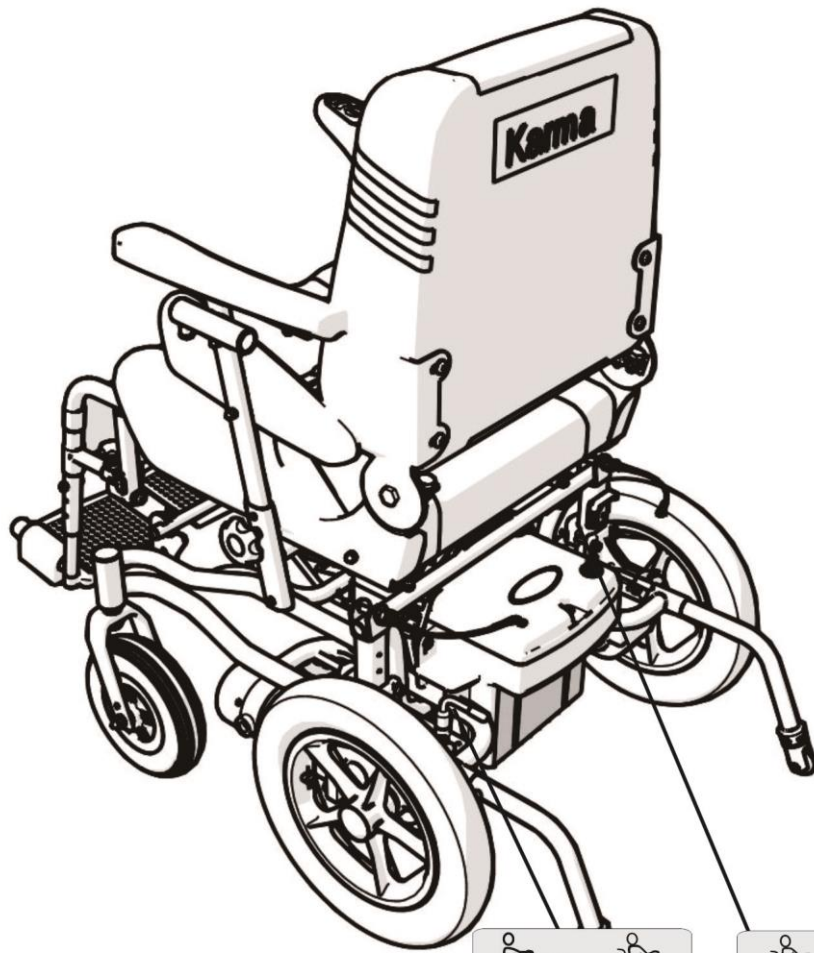

 If there are any problems or unusual situations with the battery or power system, please contact your KARMA wheelchair dealer for help. NEVER disassemble or repair the battery, otherwise, injury or damage may occur. This will negate the warranty.



Battery pack

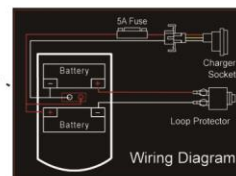

Wiring Diagram
(inside)

3. EMI/RFI

This section provides the user with basic information about the problems with EMI, known sources of EMI and protective measures either to reduce the possibility of exposure or to minimize the degree of exposure. This section also shows some conditions in which unexpected or erratic wheelchair movements may occur.



WARNING

● **It is very important that you read this information regarding the possible effects of electromagnetic interference on your electric KARMA wheelchair.**

3.1 Electromagnetic Interference From Radio Wave Sources

- 3.1.1 Powered vehicles may be susceptible to electromagnetic interference (EMI), which is interfering electromagnetic energy (EM) emitted from sources such as radio stations (Radio Frequency Interference), TV stations, amateur radio (HAM) transmitters, two-way radios, and cellular phones. The interference (from radio wave sources) can cause the powered vehicle to release its brakes, move by itself, or move in unintended directions. It can also permanently damage the powered vehicle's control system. The intensity of the interfering EM energy can be measured in volts per meter (V/m). Each powered vehicle can resist EMI up to a certain intensity. This amount of resistance is called its immunity level. The higher the immunity level, the greater the protection. At this time, current technology is capable of achieving at least a 20 V/m immunity level, which would provide useful protection from the more common sources of radiated EMI. This powered vehicle model, with no further modification, has an immunity level of 20 V/m without any accessories.
- 3.1.2 There are a number of sources of relatively intense electromagnetic fields in our everyday environment. Some of these sources are obvious and easy to avoid. Others are not apparent and exposure could be unavoidable. However, we believe that by following the warnings listed below, your risk to EMI can be greatly minimized.

3.2 The sources of radiated EMI can be broadly classified into three types

3.2.1 Hand-held portable transceivers (transmitter-receivers) with the antenna mounted directly on the transmitting unit, such as citizens band (CB) radios, walkie-talkies, security and fire or police transceivers, cellular telephones and other personal communication devices;

NOTE:

Some cellular telephones or similar devices transmit signals while they are ON, even though they are not in use.

3.2.2 Medium-range mobile transceivers used in police cars, fire trucks, ambulances and taxis usually having the antenna mounted on the outside of the vehicle; and

3.2.3 Long-range transmitters and transceivers, such as commercial broadcast transmitters (radio and TV broadcast antenna towers) and amateur (HAM) radios.

NOTE:

Other types of hand-held devices (cordless phones, laptop computers, AM/FM radios, TV sets, CD players, cassette players, and small appliances such as electric shavers and hair dryers, et cetera) so far as we know, are not likely to cause EMI problems.

3.3 Powered Vehicle Electromagnetic Interference (EMI)

3.3.1 Because EM energy rapidly becomes more intense as one moves closer to the transmitting antenna (source), the EM fields from hand-held radio wave sources (transceivers) are of special concern. It is possible to unintentionally bring high levels of EM energy too close to the powered vehicle's control system while using these devices. This can affect your powered vehicle's movement and braking.

3.3.2 Therefore, the warnings listed below are recommended to prevent possible interference with the control system of the powered vehicle.

3.4 Warnings

- 3.4.1 Electromagnetic interference (EMI) from sources such as radio and TV stations, amateur radio (HAM) transmitters, two-way radios and cellular phones can affect powered vehicles and motorized wheelchairs.
- 3.4.2 Following the warnings listed below should reduce the chance of unintended brake release or powered vehicle movement which could result in serious injury.
 - 3.4.2.1 Do not operate hand-held transceivers-receivers such as citizens band (CB) radios or turn ON personal communication devices such as cellular phones, while the powered vehicle is turned ON.
 - 3.4.1.2 Be aware of nearby transmitters, such as radio or TV stations, and try to stay away from them.
 - 3.4.1.3 If unintended movement or brake release occurs, turn the powered vehicle OFF as soon as it is safe.



WARNING

● Some stores may have automatic (sensor) doors and alarm systems set at certain frequencies that might affect your powered wheelchair.

- 3.4.3 Be aware that adding accessories/components or modifying the powered vehicle may make it more susceptible to EMI. There is no easy way to evaluate their effect on the overall immunity of the powered vehicle.
- 3.4.4 Report all incidents of unintended movement or brake release to your powered vehicle dealer or KARMA, and note whether there was a source of EMI nearby.

4. PARTS

KP-10.3S (equipped with 22Ah batteries) Parts Introduction

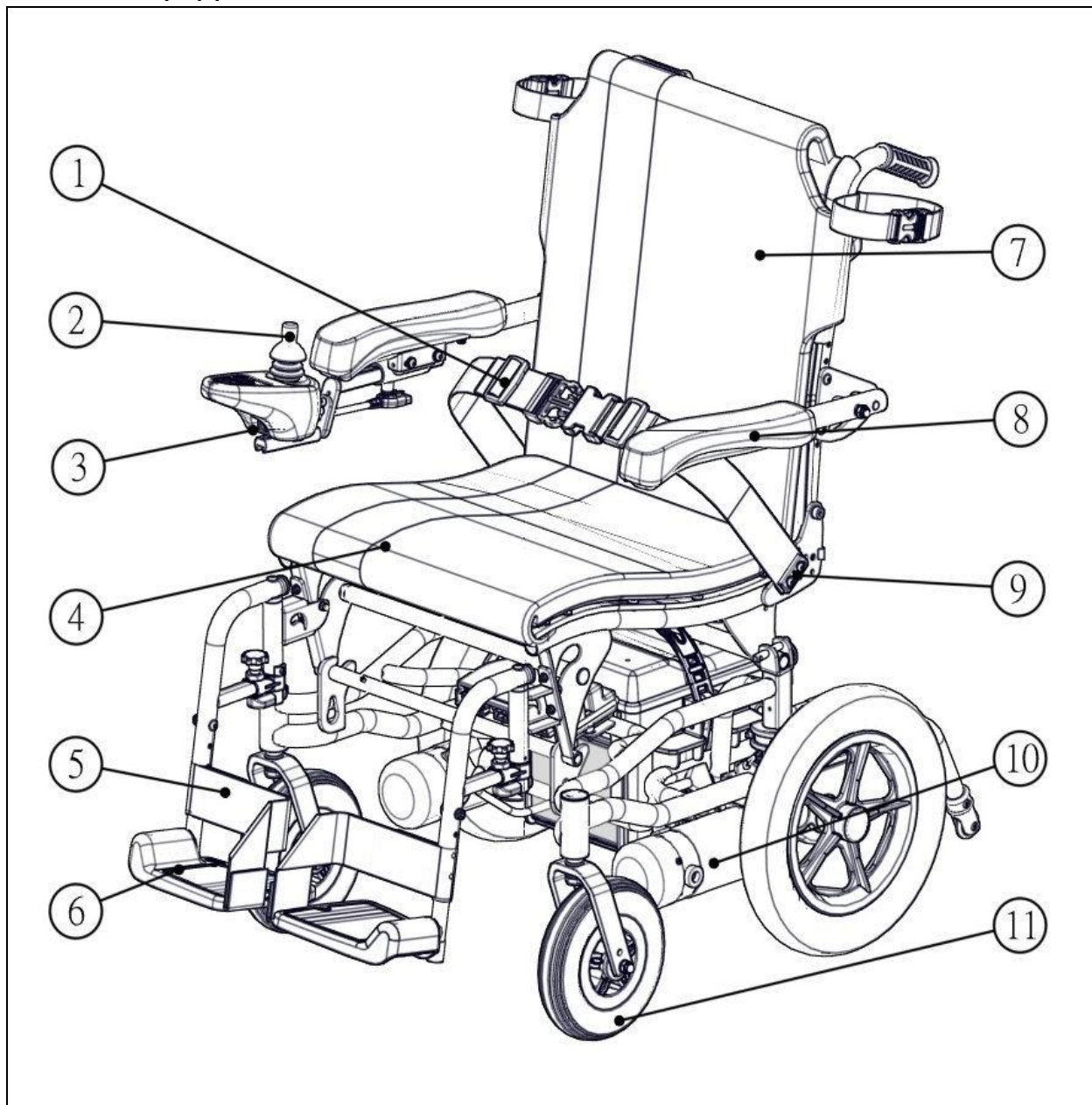

1. Pelvic Belt

2. Joystick Controller

3. Charging Socket

4. Seat

5. Heel Loop

6. Footplate

7. Backrest

8. Armrest

9. Backrest Angle Adjustment

10. Motor

11. Caster

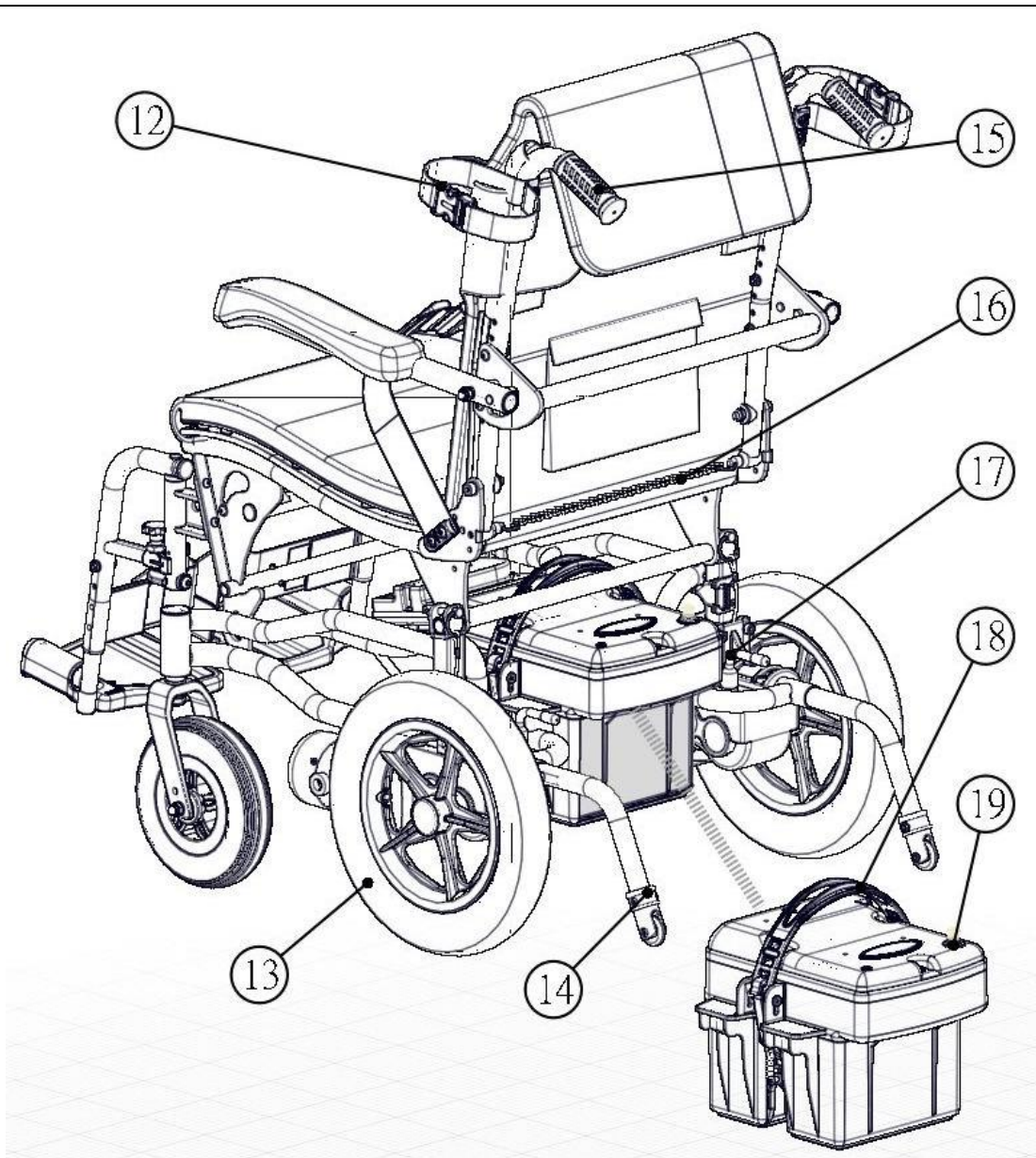

12. Armrest Fixing Strap

13. Rear Wheel

14. Anti-Tipper

15. Push Handle

16. Backrest Angle Adjustment Chain

17. Freewheel Lever

18. Battery Pack's Strap

19. Circuit Breaker

KP-10.3S Parts Introduction

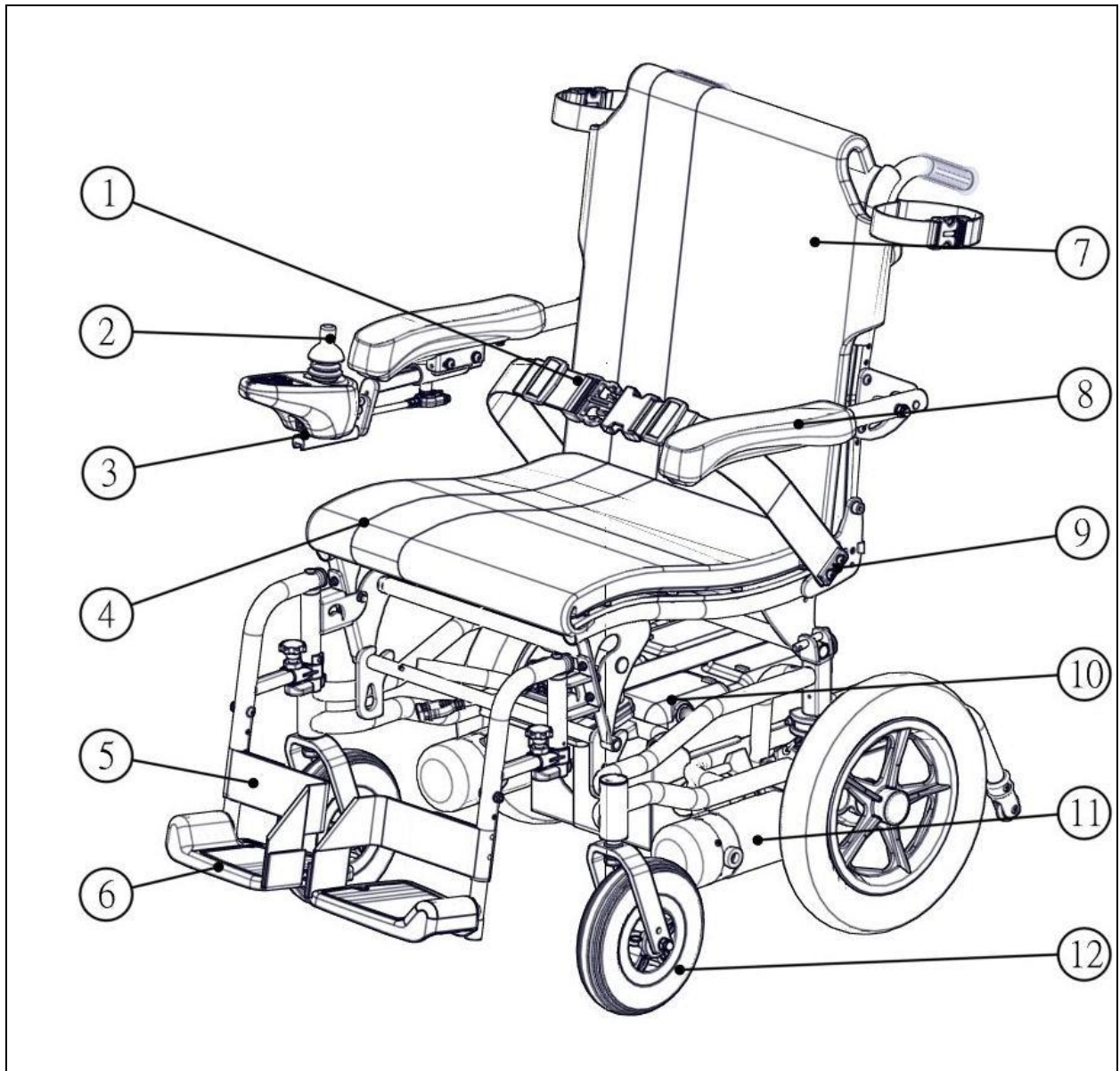

- | | |
|------------------------|------------------------------|
| 1. Pelvic Belt | 7. Backrest |
| 2. Joystick Controller | 8. Armrest |
| 3. Charging Socket | 9. Backrest Angle Adjustment |
| 4. Seat | 10. Circuit Breaker |
| 5. Heel Loop | 11. Motor |
| 6. Footplate | 12. Caster |

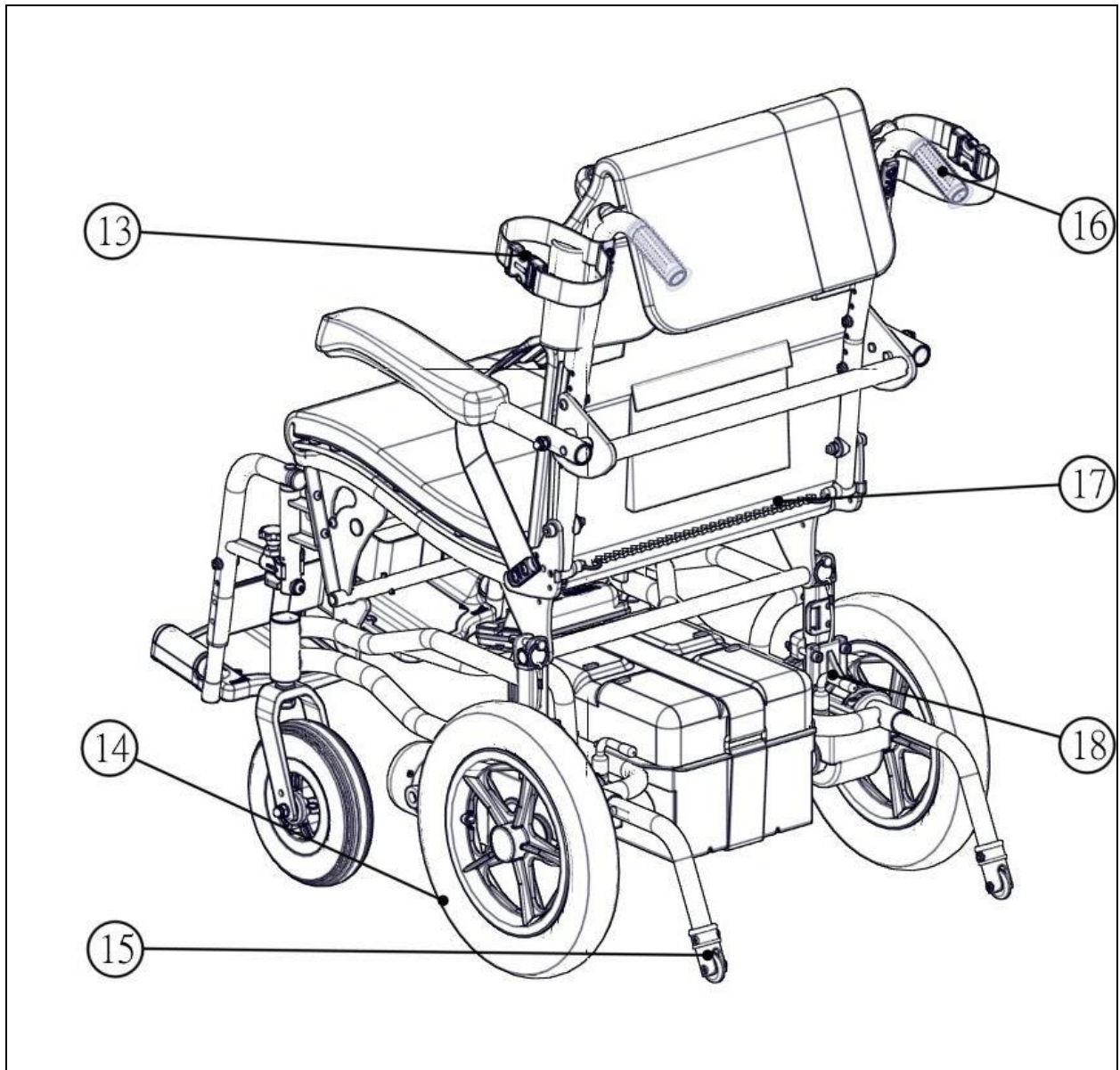

13. Armrest Fixing Strap

14. Rear Wheel

15. Anti-Tipper

16. Push Handle

17. Backrest Angle Adjustment Chain

18. Freewheel Lever

KP-10.3-CPT (equipped with 36Ah batteries) Parts Introduction

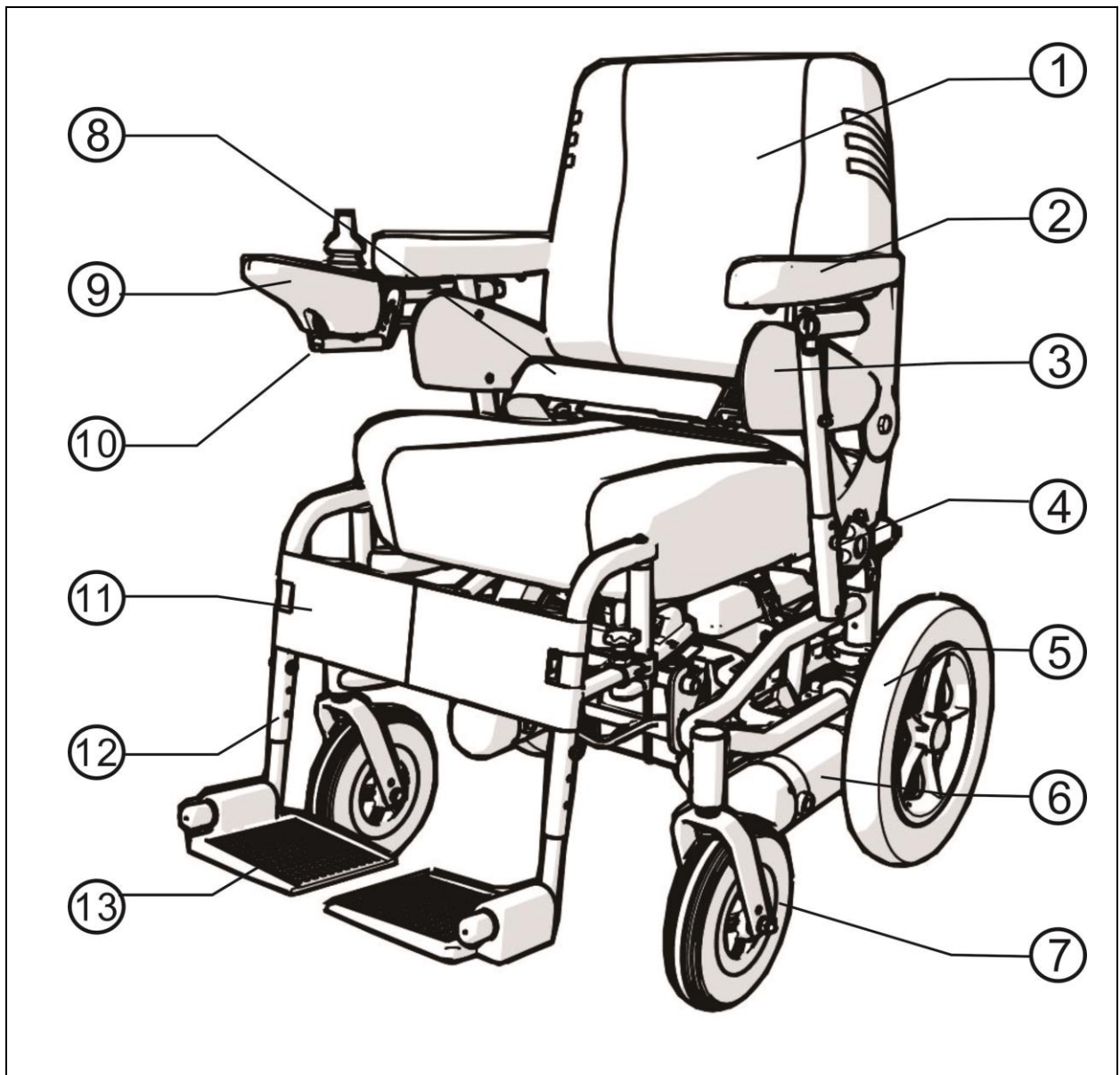

1. Seat	8. Pelvic Belt
2. Armrest	9. Joystick Contrlller
3. Side Panel	10. Joystick Controller Connection Tube
4. Armrest Height Adjusting Knob	11. Calf Strap
5. Rear Wheel	12. Footrest
6. Motor	13. Footplate
7. Caster	

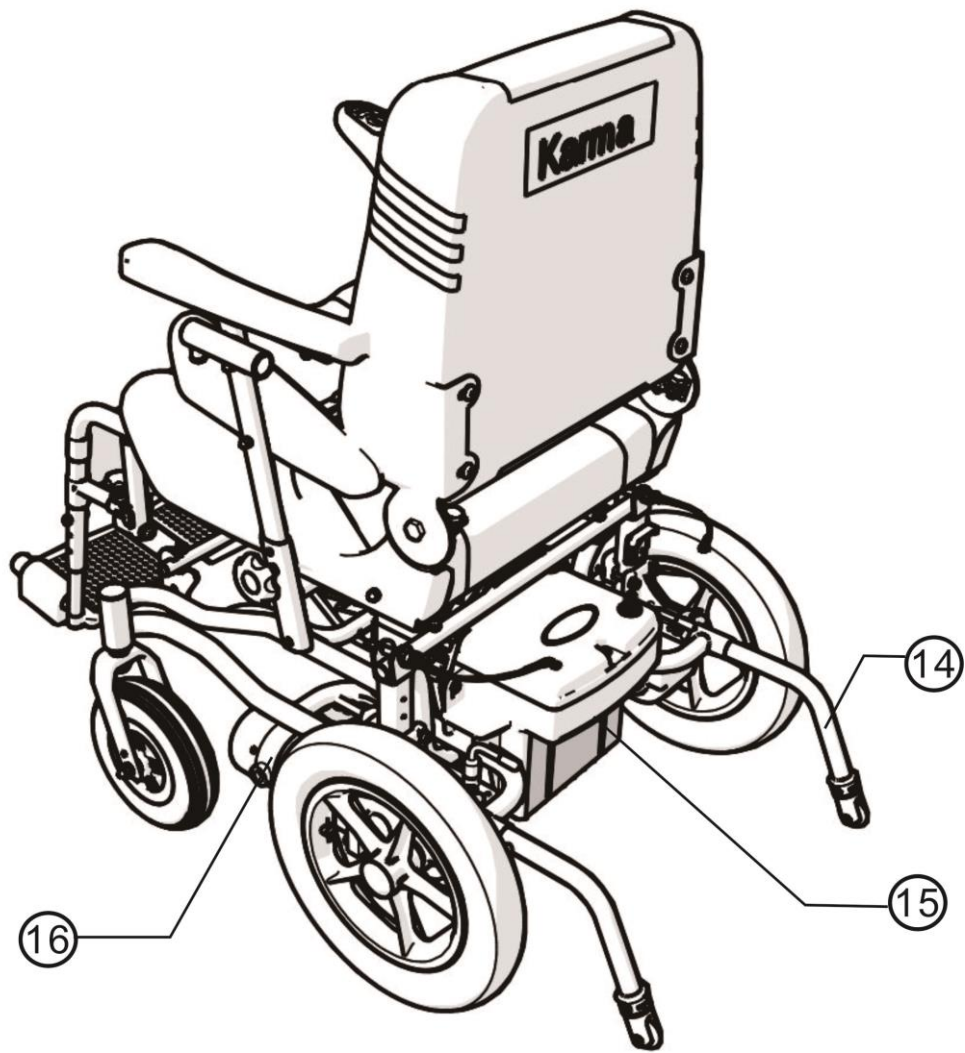

- 14. Anti-Tipper
- 15. Battery Casing
- 16. Clutch

5. OPERATION

VR II Joystick Controller

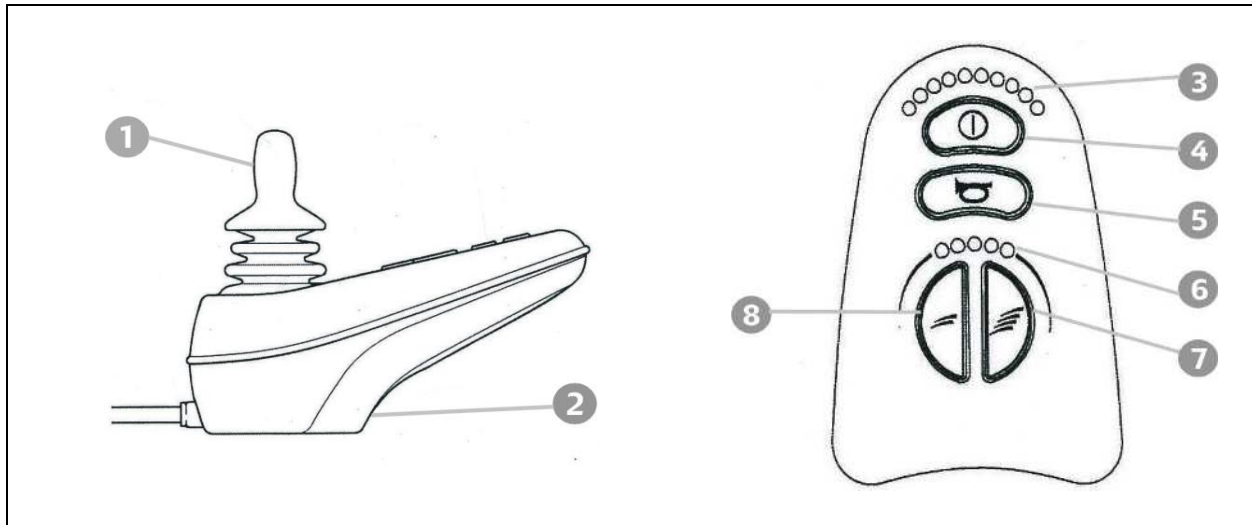

- | | |
|------------------------------------|--------------------------|
| 1. Joystick | 5. Horn Button |
| 2. Charging Socket | 6. Speed Indicator |
| 3. Battery & Diagnostics Indicator | 7. Speed Increase Button |
| 4. Power On/Off | 8. Speed Decrease Button |

Linx Joystick Controller

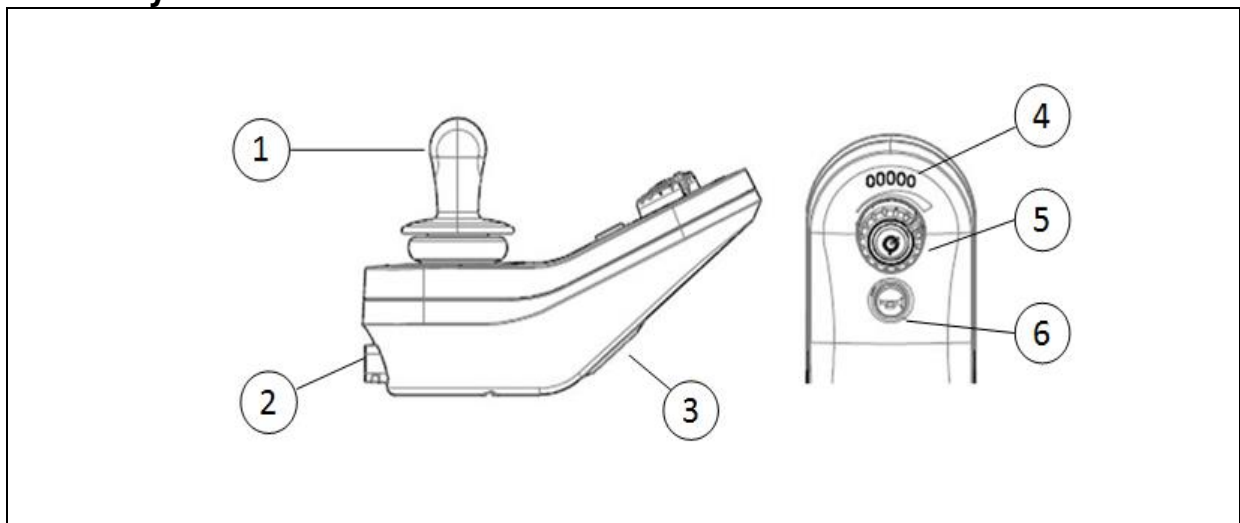

- | | |
|---------------------------|--------------------------------------------|
| 1. Joystick | 4. Battery Gauge and Diagnostics Indicator |
| 2. Socket for Power Cable | 5. ON/OFF Switch and Speed Adjustment Knob |
| 3. Charger Socket | 6. Horn Button |

5.1 How to Operate Your Wheelchair

5.1.1 POWER ON/OFF

5.1.1.1 Press the power button. Be sure not to touch the joystick while turning on the controller.

5.1.1.2 Your battery & diagnostics indicator should light up.

5.1.2 Speed Adjustment Buttons

5.1.2.1 The speed adjustment buttons allows you to set various forward and reverse speeds.

5.1.2.2 The settings are a percentage of maximum power. Notice the orange dots on the speed indicator. The more orange dots, the faster your speed.

5.1.3 Locking / Unlocking the Wheelchair

The VR2 control system can be locked to prevent unauthorized use. The locking method is via a sequence of key presses and joystick movements, as detailed below.

VR2 Joystick Controller

5.1.3.1 To lock the wheelchair

5.1.3.1.1 While the control system is switched on, depress and hold the on/off button.

5.1.3.1.2 *After 1 second the control system will beep. Now release the on/off button.

5.1.3.1.3 Deflect the joystick forwards until the control system beeps.

5.1.3.1.4 Deflect the joystick in reverse until the control system beeps.

5.1.3.1.5 Release the joystick, there will be a long beep.

5.1.3.1.6 The wheelchair is now locked.

5.1.3.2 To unlock the wheelchair

5.1.3.2.1 Use the on/off button to switch the control system on. The maximum speed / profile indicator will be rippling up and down.

5.1.3.2.2 Deflect the joystick forwards until the control system beeps.

5.1.3.2.3 Deflect the joystick in reverse until the control system beeps.

5.1.3.2.4 Release the joystick, there will be a long beep.

5.1.3.2.5 The wheelchair is now unlocked.

Linx Joystick Controller

5.1.3.3 To lock the wheelchair

5.1.3.3.1 Press the Power button for 4 seconds.

5.1.3.3.2 the battery gauge will indicate the transition by flashing LEDs 1, 3, and 5(far left, middle, and far right) 3 times.

5.1.3.4 To unlock the wheelchair

5.1.3.4.1 When the power is off, press the Power button once.

5.1.3.4.2 press the Horn button twice—the Horn button must be pressed twice within 10 seconds of pressing the power button.

5.2 Controller Cable Fastening Position

5.2.1 The controller for KP-10.3 Series is packaged in the carton; after opening the carton, the controller needs to be put into the position with fastening the cable tie.

5.2.2 Please follow the following steps

5.2.2.1 Fasten the controller on the fixing bar.(Figure 5-1, Figure 5-2)

5.2.2.2 Untighten screw B slightly. Adjust the location of the controller to fit the user's need. Retighten screw B



(Figure 5-1)

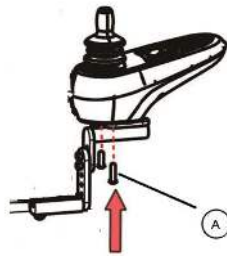

(Figure 5-2)



(Figure 5-3)



CAUTION:

- Please make sure the the cable is appropriate routed so that adjusting the location of the controll or flipping back the armrest could not damage the cable or cause malfunctions of the wheelchair.

5.3 Driving Speed

You can choose between 1 to 5 orange dots in the speed indicator, with 5 being the maximum speed. Please refer to "Max. Speed" in section 10. SPECIFICATIONS.

Speed Scale	Speed Equivalencies and Recommended Circumstances
1-2	Speed equivalent to walking slowly on foot On an decline Driving indoors or in a narrow space
3-4	Equivalent to walking at a normal speed Driving outdoors on flat ground
5	Speed equivalent to a brisk walk Driving in an open space On an incline

WARNING

- Please slow down before you get used to control your powered wheelchair.
- Please slow down your speed when indoor.

5.4 Forward, Reverse and Braking

5.4.1 Release the joystick and the electromagnetic brake will stop the vehicle

5.4.2 Come to a complete stop before turning the power OFF.

5.4.3 Push forward on the joystick to make the wheelchair move forward. (See the figure at the right)

5.4.4 Pull back on the joystick for the wheelchair to move backward.

5.4.5 Release the joystick and the wheelchair will quickly slow down, the electromagnetic brake will be activated to stop the wheelchair.

5.4.6 Come to a complete stop before turning the power OFF.

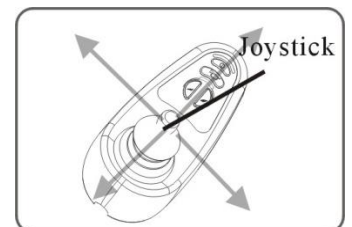

WARNING

- The stopping distance will vary with your forward/reverse speed. Therefore, please gradually slow down and come to a complete stop well before any obstacles or danger.
- To park the wheelchair, be sure to park on flat ground and then turn the power to OFF.
- NEVER use the freewheel mode when going down an incline. The electromagnetic brake won't function in freewheel mode.

5.5 Horn Button

The horn will sound for as long as the button is pressed.

5.6 Battery Gauge

When the Battery Gauge is used to indicate power on and provides an estimate of the remaining battery capacity. Any green LEDs lit indicate well-charged batteries. If only amber and red LEDs are lit, the batteries are moderately charged. Recharge before undertaking a long trip. If only red LEDs are lit, the batteries are running out of charge. Recharge as soon as possible.



SUGGESTION

- It is recommended that you charge the batteries immediately when the battery indicator shows only three or less red lines.
- After charging or replacing new batteries, drive the wheelchair for 2-3 minutes to make sure the batteries are fully charged before going on a long journey.
- In wintertime, the batteries may respond slowly and the drive range may also be reduced. You must store your wheelchair indoors above freezing temperatures.
- When driving on an incline, the battery indicator light might move up and down. This is normal.
- Even if the batteries are used properly their capacity will decay over time, thereby reducing the drive range (maximum distance traveled per full charge). Thus, when the drive range becomes about 50% of what brand new batteries would offer, it's time to replace them with new batteries. Otherwise, the batteries may die unexpectedly leaving you in a possibly precarious situation.
- The drive range will be shortened when driving frequently on slopes or uneven ground, as this consumes more battery power.

5.7 Freewheel Levers

5.7.1 The is supplied with a freewheel device to allow for manual pushing of the powered wheelchair if required.

5.7.2 To select neutral from the engaged position:

Rotate the two levers located on the top of both motors, 90 degrees outward.
The wheelchair will now roll freely. (see figure 5-4)

5.7.3 To engage the motors from the neutral position:

Simply rotate the levers 90 degrees inward. (see figure 5-5)

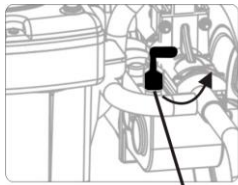

(Figure5-4)



(Figure5-5)

WARNING

- Always ensure that the freewheel levers are engaged before using the wheelchair. (i.e. Before turning on the controller)

CAUTION:

- Make sure that when the freewheel levers are released (the chair is in freewheel mode), there is an attendant for help.
- Always adjust the freewheel levers on flat ground. **DO NOT** release it on a slope (the chair is in freewheel mode) to prevent the chair from moving and causing danger.

5.8 How to Adjust Your wheelchair, Disassemble and Assemble Your wheelchair

5.8.1 Footrest Adjustment for KP-10.3

5.8.1.1 The footrest assembly can fold up and be adjusted.

5.8.1.2 Your footplate length should be adjusted according to your calf length.

5.8.1.3 Go to your service provider for adjustment or use the Allen Wrench included in your KARMA Tool Kit to loosen the bolts at both side of the footplate, adjust and re-tighten.

5.8.1.4 There are three holes in the inner frame that the lower bolt of the outer frame will go through to secure the appropriate footrest height. (See Figures 5-6~5-7) The three staged adjustment can be made in increments of 2 cm.

5.8.1.5 If you do not want use the footplate. You can fold up and put the footplate under the seat.(See figure 5-8~5-10)

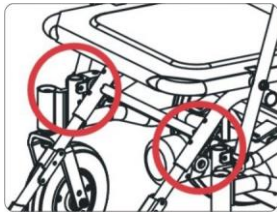

(Figure 5-6)

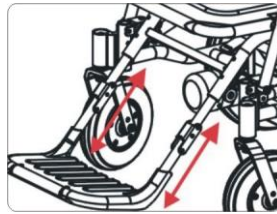

(Figure 5-7)



(Figure 5-8)



(Figure 5-9)



(Figure 5-10)

5.8.2 Footrest Adjustment for KP-10.3S/KP-10.3-CPT

5.8.2.1 The calf length can be adjusted by changing the footplate height. The adjustment is in increments of 2.5 cm (4 positions).

5.8.2.2 Your footplate length should be adjusted according to your calf length.

5.8.2.3 Use the Allen Wrench included in your KARMA Tool Kit to loosen the bolts at both side of the footplate, adjust and re-tighten. (see figure 5-11 and 5-12)



(Figure 5-11)



(Figure 5-12)



(Figure 5-13)

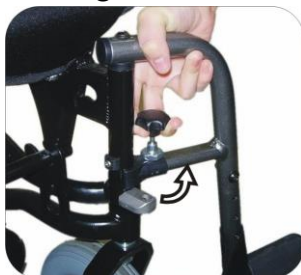

(Figure 5-14)



(Figure 5-15)

5.8.2.4 To detach the footrest, please follow below instructions.

5.8.2.5 Pull up the star knob under the seat. (see figure 5-13)

5.8.2.6 Swing the footrest outward. (see figure 5-14)

5.8.2.7 Lift the footrest up to detach it. (see figure 5-15)

5.8.2.8 Follow the above instructions to detach the footrest at the other side.

5.9 Armrest Adjustment for KP-10.3 Series

5.9.1 Height adjustments (4 stages of height adjustment) :

5.9.1.1 Remove the bolts from the armrest fitting tube, adjust to the desired height and tighten the bolts securely. (see figure 5-16)

5.9.2 Swing backwards :

5.9.2.1 To make side transfers easy, the chair is equipped with swing away armrests.

5.9.2.2 Lift and swing backwards to remove. (see figure 5-17)



(Figure 5-16)



(Figure 5-17)

5.9.3 KP-10.3- CPT Height adjustments (4 stages of height adjustment) :

5.9.3.1 Loosen the knob and adjust the height to meet the user's needs. Each stage is 2cm. After adjustment, retighten the knob. (see figure 5-18, figure 5-19)

5.9.4 KP-10.3- CPT width adjustments (4 stages of height adjustment) :

5.9.4.1 Use an Allen key to loosen the screw and adjust the width to meet the user's need. After adjustment, retighten the screw. (see figure 5-20, figure 5-21)



(Figure 5-18)



(Figure 5-19)



(Figure 5-20)



(Figure 5-21)

5.10 KP10.3 -CPT Seat position adjustment

5.10.1 The seat can be adjusted forward or backward with respect to the base frame to meet the user's needs. Use an Allen key to loosen the four screws under the seat.

Adjust the seat forward or backward according to the user's needs,

5.10.1.1 Detach the chair from the frame and loosen the screws of the seat. (See Figure 5-22)

5.10.1.2 You'll see the seat platform. (See Figure 5-23)

5.10.1.3 Adjust the seat depth you want. (See Figure 5-24)

5.10.1.4 Tighten the screws. (See Figure 5-25)



(Figure 5-22)



(Figure 5-23)



(Figure 5-24)



(Figure 5-25)

5.11 Backrest Adjustment for KP-10.3 Series

5.11.1 There are two angles for the KP-10.3/KP10.3S seat. You don't need any tools. You can adjust it by adjustment rod on the side of seat. Pull the backrest angle adjustment chain and adjust the backrest to the optimum angle. (see figures 5-26)

5.11.2 here are two angles for KP-10.3- CPT seat. You can adjust it by seat angle adjustment buttons on the side of seat. Pull the seat angle adjustment buttons and adjust the optimum angle. (see figures 5-27, figures 5-28)



(Figure 5-26)



(Figure 5-27)



(Figure 5-28)

5.12 Disassembling and Assembling the KP-10.3 Series

WARNING

- Make sure to remove the cable from the transmission connector before disassembling the wheelchair. Otherwise, the cable could be damaged.

5.12.1 Disassembling and Assembling KP-10.3

The KP-10.3 can be disassembled into three parts easily and can also be quickly assembled which is convenient for storage and transportation. Please follow the following steps.



1. Fold the footrest upward.



2. Flip back both the armrest, and buckle up the straps.



3. Pull the chain behind the seat.



4. Fold the backrest forwards and press it.

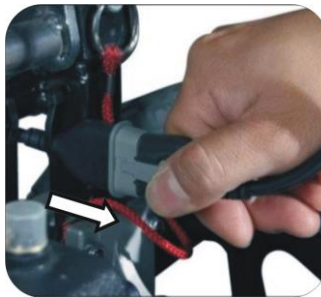

5. Remove the cable from the transmission connector.

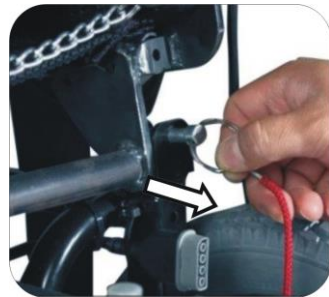

6. Pull the pins out from both sides of the mounting bases.



7. Pull the seat forward and upward to lift it.



8. Hold onto the battery pack's strap and lift it up.

- Assemble the KP-10.3 by reversing this procedure.

WARNING

- The heaviest component is base which weighs 24 kg.
- Please be careful about hands' injury when assembling and disassembling.
- Always use the anti-tippers on your wheelchair to prevent injury.

5.12.2 Disassembling and Assembling KP-10.3S

The KP-10.3S can be disassembled into three parts easily and can also be quickly assembled which is convenient for storage and transportation. Please follow the following steps.



1. Detach the footrests.



2. Flip back both the armrest, and buckle up the straps.



3. Pull the chain behind the seat.



4. Fold the backrest forwards and press it.



5. Remove the cable from the transmission connector.



6. Pull the pins out from both sides of the mounting bases.



7. Pull the seat forward and upward to lift it.



8. Unfasten the velcro from the bottom of the battery box.



9. Open the battery box cover to the left.



10. Unplug the battery.



11. Lift up the battery by its handle.



12. After removing the batteries, close the battery box cover.



- When your KP-10.3S is equipped with 22Ah batteries, to remove the batteries, simply hold onto the battery pack's strap and lift it up. (as shown in the step No. 8 in section 5.11.1 Disassembling and Assembling KP-10.3)↵
- Assemble the KP-10.3S by reversing this procedure.↵
- Battery plugs are placed in the gap between the two batteries, as shown in the left figure.↵

5.13 Disassembling and Assembling KP-10.3-CPT



CAUTION

- Make sure that the brake are engaged to prevent the chair from sliding during assembly and disassembly.
- The seat of KP-10.3S can be locked when assembly. Do not over-force when folding and unfolding. It might cause injury or damage the wheelchair structure.
- The battery weighs about 12 kg, make sure that you have sufficient strength to lift it up.
- To unplug the controller wire (see the figure at the right), press down the front side of the plug. Then pull it back to detach it. When plugging it, note that the front of the plug should face inward of the wheelchair (as the the same direction as it faces when it is still plugged) and plug it in. The direction of the plug should be maintained. Otherwise, it might damage the plug, and such damage is not covered by the warranty.

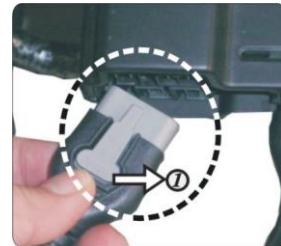

1. Disconnect controller wire.↵



2. Detach the footrests.↵



3. Pull the backrest angle adjusting lever and fold the backrest forward.↵



4. Pull the pins out from both sides of the mounting bases.↵



5. Lift and pull the seat backward to remove it from the base frame.↵



6. Unfasten the Velcro from the bottom of the battery box.↵



7. Open the battery box cover to the left.



8. Unplug the battery.



9. Lift up the battery by its handle.



10. After removing the batteries, close the battery box cover.

5.14 Anti-Tippers

The main purpose of anti-tippers is to prevent the user from turning over.

5.14.1 The release pin should be protrudent once you have installed the anti-tippers.

Please try to pull forward and backward to check if the anti-tippers are immovable



CAUTION

- If the anti-tip tubes are not fitted, or have been fitted incorrectly, there is a risk of tipping over and of injury.

5.15 Getting In and Out

5.15.1 The freewheel levers are above the motors in the back of the wheelchair. Note that they should be engaged when the user gets in and out of the wheelchair to prevent it from sliding.

5.15.2 Flip up the footplate when getting in and out. It can prevent the chair from tipping to the front and make transferring easier.

5.15.3 Make sure that the controller is turned off.



CAUTION

- Always ensure that the front casters are in line with the rear wheels and pointing forwards and that the back of the chair is secure either against a wall or firmly held by an attendant.

5.16 Getting In

- 5.16.1 Engage the freewheel levers and make sure that the controller is turned off.
- 5.16.2 Turn up the foot plates and swing footrest to the side.
- 5.16.3 The user should now lower themselves into the seat using the armrests as supports.
- 5.16.4 Turn the foot plates back down and re-locate the footrests so that the user can place his feet upon them.

5.17 Getting Out

- 5.17.1 Make sure that the chair is as close as possible to your transfer point.
- 5.17.2 Back the chair sufficiently to ensure that the casters are pointing forward i.e. in line with the rear wheels and usually with the caster forks pointing forward. Ensure that where possible the rear of the chair is against a wall or, if not, it must be firmly held by an attendant.
- 5.17.3 Engage the freewheel levers and make sure that the controller is turned off.
- 5.17.4 Turn up the foot plates and swing the footrests to the side.
- 5.17.5 Slide forwards on the seat.
- 5.17.6 Place one foot firmly on the ground with the knee at a right angle and the other foot slightly apart and further back.
- 5.17.7 Place your hands on the front of the armrests and moving your weight forward, bring your head and shoulders up over your knees as you push yourself up.



CAUTION

- Never stand on the footplates when getting into or out of the chair.
- Always ensure that the front casters are in line with the rear wheels and pointing forwards and that the back of the chair is secure either against a wall or firmly held by an attendant.

6. BATTERIES AND CHARGER

6.1 Battery Box of 22 Ah batteries in KP-10.3 Series

There are two batteries that are connected and put below the wheelchair within the battery box of KP-10 series. This battery boxes are designed professionally, can disassemble and combine fast. When the wheelchair is disassembled, remove the seat first. Hold onto the battery pack's strap and lift it up. It can be in accordance with going on against the step to put the battery. (See Figures 6.1 ~ 6.3)



1. Put the battery box single-handed and vertically. (Figure 6-1)
2. Notice that the battery box can't bump against the pole. (Figure 6-2)
3. Please check the tight between the battery box and frame. (Figure 6-3)

WARNING

- Please read the owner's manual that is included with the charger that came with your powered wheelchair. The information in the original manufacturer's owner's manual supersedes any information given in this chapter since the charger included with our products may change from time to time.

6.2 Charging the Batteries

6.2.1 Charge your batteries if any of the following conditions occur.

6.2.1.1. If you have used your wheelchair for more than an hour continuously.

6.2.1.2. You've used more than one quarter of the total charge.

6.2.1.3. When you haven't used the wheelchair for more than two weeks.

6.2.1.4. If the current charge is not enough to reach your final destination.

6.2.2 Be sure to follow the procedures listed below precisely.

6.2.2.1 Turn the wheelchair OFF.

6.2.2.2 Connect the charger's cord to a power outlet.

6.2.2.3 Locate the charging socket at the front of the joystick housing. Then connect the charger's round plug to the charging socket. (see figures 6-4 and 6-5)

6.2.2.4 The charger's red/orange LED will light up as soon as the charging starts.

6.2.2.5 The charging time is at least 8 hours, but it could be as long as 12 hours, depending on the status of the batteries and temperature. The charging time is 16 hours in maximum.

6.2.2.6 The orange LED will change to green when the charging is completed.

6.2.2.7 Disconnect the cord and pull out the round plug from the charging socket.

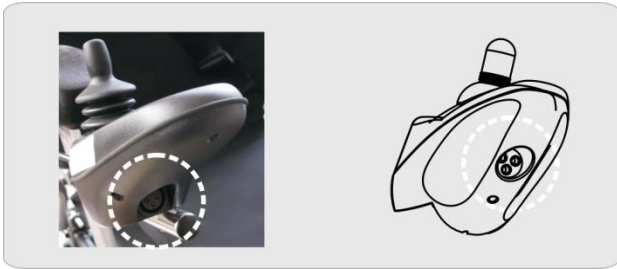

(Figure 6-4)



(Figure 6-5)

SUGGESTION

- Do not disconnect the charger cord if the charging is not completed. The battery life will be seriously shortened or decayed if the batteries are repeatedly used without being fully charged. Therefore, be sure to always charge the batteries fully.
- Always complete the charging by letting the charge LED light turn green. NEVER stop charging before it is complete.
- When finished charging, disconnect the charger plug from the charging socket as soon as possible. Even when the charger is turned OFF, the electric power will slowly discharge if the cord is not disconnected. DO NOT leave the charger ON connected to the wheelchair for more than 16 hours.
- Charging time depends on the surrounding temperature; it takes longer in the winter.

CAUTION

- Please follow the guidelines below to avoid accidents while charging.
- Be sure to only use a KARMA approved battery charger and charge the battery completely every time. The battery can be damaged if a non-genuine charger is used.
- Never disassemble or modify the charger. This will void the warranty.
- Please charge in a well-ventilated area where the battery is not directly exposed to sunlight. Do not charge the battery under rainfall, in morning dew or in an area where the humidity is high.
- Do not cover the wheelchair with any waterproof cloth or other objects while charging. Don't charge in temperatures less than -10°C (14°F) or higher than 50°C (122°F) as the charger may not work well and the battery may become damaged.
- The charger is not guaranteed to be water resistant.
- Valve Regulated Lead-Acid batteries do not have a memory function like cell phone batteries have. Please get in the habit of recharging your VRLA batteries frequently.
- New batteries MUST be fully charged prior to initial use of the powered wheelchair.
- Always charge new batteries before initial use or battery life will be reduced.

- As a general rule, recharge batteries as frequently as possible to assure the longest possible life and to minimize required charging time. Plan to recharge them when use of the powered wheelchair is not anticipated.

WARNING

- Keep your wheelchair away from flammable objects while charging, as it may lead to fire or explosion of the battery.
- Since the battery may produce hydrogen, do not smoke while charging and charge in a well-ventilated area.
- Never connect or disconnect the plug (cord) with wet hands or if the plug (cord) is wet to avoid possible electric shock.
- Never attempt to recharge the batteries by attaching cables directly to the battery terminals or clamps. **DO NOT** jump start your wheelchair!
- **DO NOT** attempt to recharge the batteries while the powered wheelchair is in operation.

6.3 Charger

6.3.1 The charger's red/orange LED will be ON during charging.

6.3.2 The red/orange LED will turn green when the charging is completed.

6.4 Batteries

6.4.1 Charging or storing the vehicle. Exceeding the specified temperature range can lead to either freezing or overheating of the batteries.

6.4.2 This will damage the batteries and shorten their lives.

6.4.3 The batteries used on your wheelchair are maintenance free sealed lead acid batteries. Thus, it is not necessary to change or refill the battery liquid.

CAUTION

- Place the powered wheelchair in a well-ventilated area where work can be performed without risking damage to carpeting or floor covering.
- Failure to use the correct battery size and/or voltage may cause damage to the powered wheelchair and give unsatisfactory performance. For replacement of batteries, please contact your local KARMA supplier/dealer in order to ensure that the new batteries are correctly be used.



WARNING

- Do not open the battery seal cap at any time.
- After ANY adjustments, repair or service and BEFORE use, make sure that all hardware is tightened securely. Otherwise, injury or damage may occur.
- When removing/installing batteries, keep all foreign objects, especially metal, away from battery terminals.
- There are many risks involved with improper disposal of batteries, whether damaged or not. Batteries may contain heavy metals and be considered hazardous waste. Many regions around the world now strictly enforce laws to help protect our environment. By not disposing of batteries properly, you may be liable for fines from your local through national government.
- By not recycling batteries, they end up in landfills that are already low on space. From these landfills, lead and other chemicals may leach into streams and rivers destroying ecosystems and poisoning local water resources.
- Improper disposal of batteries may also cause injury to unsuspecting others that come in contact with them. If you come in contact with fluids or corroded powder from a battery, rinse with water and contact a physician if necessary. If contact with eyes occurs, rinse for 15 minutes and then visit a physician.
- Incinerating or burning a battery will cause it to explode! Please see the end of Section 11. Cleaning & Recycling for more information.
- Do not use an extension cord when charging your batteries.
- A risk of fire and /or electric shock could be encountered.

7. INSPECTION AND MAINTENANCE

7.1 Daily Check

Check the following items before driving. If you find anything abnormal, visit your KARMA wheelchair dealer for further inspection before using it.

Item	Inspection Content
Joystick Controller	Is the joystick loose and/or making noise? Can the joystick be turned left and right smoothly? Can the speed buttons be adjusted freely and do they function well? Does the wheelchair stop when the joystick is released completely? Does it light up when the power is ON? Is there enough power for your trip? Does the horn work well?
Motor	Is there any abnormal noise? Does the electromagnetic brake work properly?
Freewheel Mode	Do the freewheel levers work properly?
Driver's Seat	Do the seat angle adjustment knobs (or buttons) work properly? Does the surface of the seat remain or break?



WARNING

- Visit a KARMA wheelchair dealer for inspection and maintenance if you find anything abnormal.

7.2 Regular Maintenance Record

In order to ensure that your wheelchair is in good condition, please contact KARMA authorized dealers regularly and make further wheelchair inspection and maintenance records. We recommend that you inspect and maintain your wheelchair **every six months**.



SUGGESTION

- Even if you don't use the wheelchair for a long time, the wheelchair should still be maintained regularly.
- You should clean your wheelchair, inside and out, regularly to keep it clean and safe.

I - Inspection A - Adjustment Δ - Repair
 3 - Replacement T - Tightening L - Add Oil

Item/Period		1 mth	6 mth	12 mth	18 mth	24 mth	30 mth
Joystick Control Unit			I	I	I	I/3	I/3
Power Module			I	I	I	I/3	I/3
Controller Buttons			I	I	I	I/3	I/3
Connection to the Electrical System				I		I	I/A
Motor	Operation and Noise		I	I	I/A	I/A	I/3
	Electromagnetic Brakes		I	I	I	I/3	I/3
	Connection to the Electrical System			I		I	
Batteries	Loose or Corroded Terminals			I		I	
	Connection to the Electrical System			I		I	
	Damage to the Electrical Cord/Cable			I		I	
Charger	Charging Function and LED Light	I	I	I	I/Δ	I/Δ	I/Δ
	Socket, Plug and Cords			I		I	
	Fan Functions Properly (if applicable)			I		I/Δ	
Tires	Cracks/Surface Damage	I/3	I/3	I/3	I/3	I/3	I/3
	Tread Depth		I	I/3	I	I/3	I
	Abnormal Wear Pattern			I/3		I/3	
Wheel Rim	Tightness of Bolts and Nuts			T		T	
	Wear or Deformation Around Tires			I/3		I/3	

7.3 Tires

7.3.1 The condition of the tires is affected by the way you drive and use your wheelchair.

7.3.2 Inspecting Tire Tread: please check the tread depth regularly. Replace the tires when the tread depth is less than 0.5 mm.

7.4 General Maintenance

7.4.1 You must maintain the vehicle more frequently if you drive on grass, sand or gravel roads often.

7.4.2 Do not use water, oil or other chemical solutions to clean your wheelchair. Be sure NOT to spray the vehicle with water, as not to damage the electronic components and PCB circuit board.

7.4.3 Please clean the vehicle by wiping it with either a dry or moist cloth.

7.4.4 Please take the vehicle to an authorized KARMA wheelchair dealer for repairs and adjustments. Improper adjustments could lead to wheelchair malfunction or an accident.



CAUTION

- Before performing any maintenance, be sure to turn the power OFF and unplug the charger if connected.
- DO NOT over-tighten any hardware. This could cause damage to the frame and hardware.



SUGGESTION

- Do not directly spray water on your wheelchair to wash it, as this could lead to a malfunction in the electric system.
- Do not use gasoline, solvents or other abrasive solutions; the casing may become deformed or damaged.



WARNING

- After ANY adjustments, repair or service and BEFORE use, make sure that all hardware is tightened securely, otherwise injury or damage may occur.

7.5 Suggested Maintenance Procedures

7.5.1 Before using the powered wheelchair, make sure all nuts and bolts are tight.

7.5.2 Check all parts for damage or wear and have a qualified technician replace it if necessary.

7.5.3 Check all parts for proper adjustment.

7.5.4 Ensure that the batteries are properly maintained and charged as required.

7.5.5 Inspect brake for proper operation.

- 7.5.6 The wheels and tires should be checked periodically for cracks and wear, and should be replaced by a qualified technician.
- 7.5.7 Regularly check for loose nuts and/or bolts in the front and rear wheels. If loose, have them adjusted by a qualified technician.
- 7.5.8 Clean dirt, dust and grease from exposed components.
- 7.5.9 A qualified technician can be found with an authorized distributor/dealer.

7.6 KP-10.3 Series Instructions for Lubrication

Please view below for the instruction of lubricating the parts on the wheelchair.

7.6.1 Caster Bracket (see figures 7-1)

7.6.2 Backrest Angle Adjustment Ring (see figures 7-2)

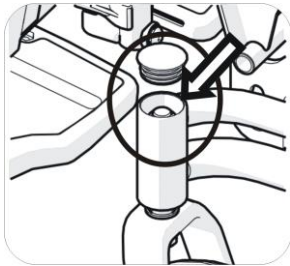

Figure 7-1

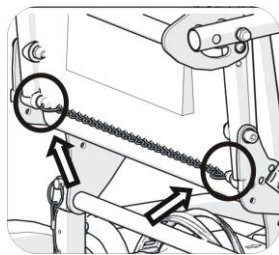

Figure 7-2



CAUTION

- Before lubrication, do clean the area.
- When lubricating, use just 1-2 drops of oil (not grease), as extra oil will fall on the rug and pollution as a result of over-lubrication.
- Depending on how often you use the chair, normally 1-2 times of lubrication per month is fine. Proper lubrication can extend the life span of a part in addition to prevent noise from accruing. Check if the bolts are fastened while lubrication.

7.7 Transporting and Storing

- 7.7.1 The wheelchair may be disassembled for ease of transport. Please refer to section 5 for more detailed information on the individual steps. Reverse the order for reassembly.
- 7.7.2 Remove the seat from the lower body. Be sure that wire connected to the controller is detached.
- 7.7.3 Remove the swing-away footrests.

7.7.4 Carry the body of the wheelchair by the front and back frame using two people.

7.7.5 Do not lift the lower body by the casing or any detachable parts

7.7.6 Please store the wheelchair in a location where it is out of direct sunlight, rain and dew.

7.7.7 When stored for a long time, please charge the batteries to full and then disconnect the battery terminals.

7.7.8 For more details, consult your KARMA wheelchair dealer.

WARNING

- **As of this date, KP-10.3 Series can NOT be used as seats in any vehicles. That is, KARMA recommends that users are NOT transported in any vehicle while seated in the wheelchair. In the case of accident or a sudden stop, the user or passengers may be at risk of getting injury. The suggested solution is to transfer the user from the wheelchair into a vehicle seat and to securely stow the wheelchair in a separate compartment.**

8. OPTIONAL ACCESSORIES

Please contact your dealers for the accessories.

CAUTION

- **DO NOT use parts, accessories or adapters other than those authorized by KARMA.**
- **Attaching accessories may alter the overall stability and centre-of-gravity of the chair. Thus, this should be performed by an authorized dealer/ technician or qualified therapist.**
- **Be aware that adding accessories/components or modifying the powered vehicle may make it more susceptible to EMI. There is no easy way to evaluate their effect on the overall immunity of the powered vehicle.**

9. TROUBLESHOOTING

9.1 Trouble or Problems with Your Wheelchair

9.2 You can inspect the following before taking your wheelchair to a KARMA wheelchair dealer.

Problem	Checking Points and Corrective Action
My wheelchair does not start.	Is the power turned OFF ? ↓ Unlocked the seat release lever.
	Do the batteries still have power? Is the battery indicator light not on? ↓ Charge the batteries.
	Is the charger plugged into the wheelchair? ↓ Unplug the charger and put it away

If you cannot solve the problem by yourself, contact your KARMA wheelchair dealer for help.

9.3 Controller, Battery& Diagnostics Indicator

If there is error with the system when it is powered up, then the status indicator will flash red; the number of flashes will indicate the type of error.

The table below describes the error indication, and a few possible actions that can be taken to rectify the problem.











The actions listed are not in any particular order and are suggestions only; the intention is that one of the suggestions may help you clear the problem. If in doubt, please consult your dealer or customer service engineers

9.3.1 The wheelchair can't be driven when there's an error that influences the safety.





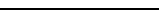

9.3.2 After the error is cleared, the wheelchair can be driven again.

9.3.3 The following table indicates what the gauge will display for any given state.

9.3.3.1 VR II Joystick Controller Diagnostics Indicator

Indication	Status	Meaning	What to do
	1 signal	The battery needs charging or there is a bad connection to the battery.	Check the connections to the battery. If the connections are good, try charging the battery.
	2 signals	The left hand motor has a bad connection.	Check the connections to the left hand motor.
	3 signals	The left hand motor has a short circuit to a battery connection.	Connect your service agent.
	4 signals	The right hand motor has a bad connection.	Check the connections to the left hand motor.
	5 signals	The left hand motor has a short circuit to a battery connection.	Connect your service agent.
	6 signals	The wheelchair is being prevented from driving by an external signal.	Please remove the charger.
	7 signals	A joystick fault is indicated.	Make sure that the joystick is in the center position.
	8 signals	A joystick fault is indicated.	Make sure that all connections are secure.
	9 signals	The parking brakes have a bad connection.	Check the parking brake and motor connections and make sure all connections are secure.
	10 signals	An excessive voltage has been applied to the control system.	Check the battery connections.
	10 signals + Speed indicator	A communication fault is indicated.	Make sure that the joystick cable is securely connected and not damaged.

9.3.3.2 Linx Joystick Controller Diagnostics Indicator

Flash code		Error description	Possible action
1		Remote joystick error	Check cables and connectors Replace the Remote
2		Network or configuration error	Check cables and connectors Recharge the battery Check charger Replace modules Contact the dealer
3		Left motor error	Check cables and connectors Replace Power Module Check and/or replace left motor
4		Right motor error	Check cables and connectors Replace Power Module Check and/or replace right motor
5		Left park brake error	Check cables and connectors Check left park brake is released Replace modules
6		Right park brake error	Check cables and connectors Check right park brake is released Replace modules
7		Module error (other than Remote)	Check cables and connectors Check modules Replace LiNX Access Key Power Module Recharge battery If the chair stalled, reverse away the chair or remove any obstacles. If the chair was moved while turned off, please wait for a few seconds and switch on the power again.

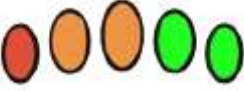
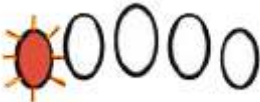
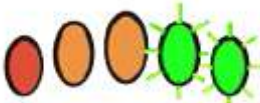
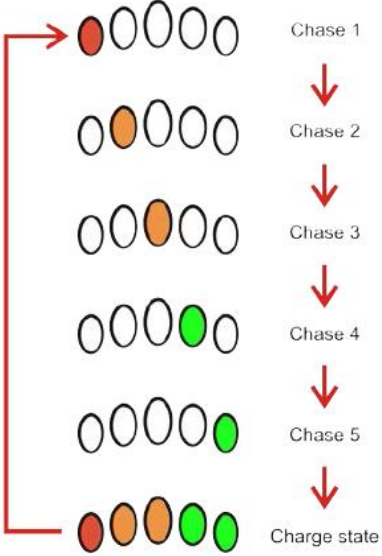
The battery gauge LEDs	Information
	Batt Gauge Maximum is indicated on the battery gauge with all LEDs lit and signifies that the battery level is somewhere between 81 and 100% of full capacity.
Batt Gauge Maximum	
	A low battery warning is generated when the battery voltage falls below the Batt Gauge Low Voltage Warning set-point. This is indicated on the battery gauge with the red (left-most) LED flashing.
Batt Gauge Low Voltage Warning	
	A high battery warning is generated when the battery voltage goes above the Batt Gauge High Voltage Warning set-point. This is indicated on the battery gauge with all LEDs lit, and the two green (right-most) LEDs flashing.
Batt Gauge High Voltage Warning	
	The Battery Gauge will indicate the system is being charged by cycling between a left-to-right chase sequence, and then displaying the approximate battery charge state at the end of the chase sequence.
Battery charging	

10. SPECIFICATIONS

Product Model	KP-10.3S	KP-10.3 CPT
Nominal seat width (in)	18	18
Front x Rear wheel size (in)	8 x 12	
Maximum user weight (kg)	120	
Overall length with legrest (mm)	1030 ~ 1075	1020
Overall width (mm)	620	615 ~ 680
Overall height (mm)	905 ~ 935	920
Folded length (mm)	660	660
Folded width (mm)	620	615
Folded height (mm)	155	418
Total mass (kg)	51.3(22 Ah) / 54.9(36 Ah)	53.3(22 Ah) / 64.3(36 Ah)
Total mass without batteries (kg)	33.5(22 Ah) / 37.8(36 Ah)	40(22 Ah) / 42(36 Ah)
Mass of the heaviest part (kg)	16.5(22 Ah) / 20.6(36 Ah)	24(22 Ah) / 26(36 Ah)
Maximum speed forward (km)	6	6
Drive range (km)	14.9(22 Ah) / 18.7(36 Ah)	14.9(22 Ah) / 18.7(36 Ah)
Minimum turning radius (mm)	885	915
Minimum turning radius without user (mm)	755	785
Reversing width (mm)	1050	1120
Ground clearance (mm)	100	100
Obstacle climbing (mm)	50	50
Static stability downhill (X°)	25.5	17
Static stability uphill (X°)	11	14
Static stability sideways (X°)	20.5	15
Dynamic stability uphill (X°)	6	
Ability to climb rated slope (X°)	6	
Braking method	Electromagnetic Brake	
Minimum braking distance from max speed (mm)	1000	
Motor power (W)	200	
Battery capacity (Ah)	22*2 / 36*2	

Charger output current (A)	4	
Battery Compartment (L x W x H) (mm)	180 x 80 x 165 (22 Ah) (Single Compartment) 200 x 135 x 155 (36 Ah) (Single Compartment)	
Seat plane angle (X°)	12	12
Effective seat depth (mm)	475	440
Nominal seat depth (mm)	460	460
Effective seat width (mm)	450	440 ~ 550
Seat surface height at front edge (mm)	540	550
Backrest angle (X°)	10 ~ 24	19
Seat to backrest angle (X°)	88 ~ 102	97
Backrest height (mm)	500	430
Headrest height above seat (mm)	-	-
Leg to seat angle (X°)	90	113
Footrest to seat distance (mm)	390 ~ 465	410 ~ 485
Armrest to seat distance (mm)	200	200 ~ 240
Front location of armrest structure (mm)	400 ~ 540	370

* All the specifications specified in this section are estimated based on the following conditions: 20°C ~35°C, an 80 kg occupant, brand new fully charged batteries and driving on the flat road.

* The actual product specifications differ from the data in the table by ± 1 cm ± 0.5 kg.

* The actual product specifications may vary according to different configurations.

* KARMA reserves the right to modify information herein without further notice.

* If you want to know more about the measurement methods of wheelchair specifications, please scan the QR code to watch the instructions on the KARMA website.



11. CLEANING & RECYCLING

11.1 Cleaning

- 11.1.1 In order to lengthen the life of your wheelchair, it is suggested that you clean the wheelchair periodically (if not daily), especially after it is used in the rain or snow.
- 11.1.2 We suggest that you don't use your wheelchair in the rain or snow.
- 11.1.3 If you are traveling and get caught in the rain, we suggest you try to find shelter and turn OFF your wheelchair while waiting it out.
- 11.1.4 If you can't find shelter, proceed to your destination.
- 11.1.5 However we do not recommend you do this often as it may shorten the life of your wheelchair or cause damage.
- 11.1.6 Driver's seat upholstery: use soapy water. Wring out the sponge/ cloth before scrubbing. Do not use the wheelchair until it is dry.
- 11.1.7 Frame: wipe with a damp cloth, but be sure not to splash/spray the wheelchair with water, as doing so may damage the motor, electrical wiring and battery.
- 11.1.8 If compressed air is available, you can use the compressed air to clean your wheelchair (do not exceed 7K and keep the nozzle at least 10 cm away from your wheelchair).
- 11.1.9 Casing: wipe with a damp cloth. After it is dry, coat the casing with a light layer of wax, if desired.

11.2 Post-Consumer Recycling

11.2.1 A post-consumer recycling plan should follow the Environmental Protection Administration's regulations.

11.2.2 The items listed below are for reference only as local law and regulation may vary.

Material	Part Name	Method
Iron/Aluminum-alloy	Frame	Recyclable
ABS	Various	Recyclable
Various	Battery	Recyclable
Various	Motor/Reduction Gear	Recyclable
Various	Electric Parts	Recyclable

11.2.3 There are many organizations in many countries you can find on the internet that will accept used goods for charity or disassemble electronic equipment and batteries to recycle them.

11.2.4 Please search the information highway to help less fortunate individuals and protect our planet for future generations.

11.2.5 If you do not have access to the world wide web please use your local phone directory, ask for operator assistance or go to your local government centre for more information. Earth Day is every day.

11.2.6 Check with your local recycling centre on where and how to recycle used batteries as this



11.2.7 Information varies from region to region.

12. WARRANTY

12.1 Serial Number

To ensure after-sale service and warranty, please record and fill in the serial number which can be found on the frame.

This warranty is VOID if the original chair serial number is removed or altered.

Model	KP-10.3 Series
Serial Number	

12.2 Contents and Duration of Warranty

12.2.1 If the parts of the product need to be repaired or replaced due to manufacturing defects, they can be repaired or replaced free of charge within the warranty period (a repair of this kind will hereafter be called warranty maintenance).

12.2.2 Frame is warranted for a period of 5 years and electrical system (controller, motor, charger, actuator and PCB) for a period of 1 year after delivery to the customer, then the affected parts will be repaired or replaced free of charge.

12.2.3 Battery warranty is subject to the periods set by the manufacturers. Please contact your local dealer in detail.

12.2.4 Consumable parts such as bearings, cables, carbon brushes, circuit breakers, covers, footplates, light bulbs, pads, side guards, upholsteries, wheels and similar parts are excluded from the warranty.

12.2.5 Warranty maintenance can be performed by authorized KARMA wheelchair dealers only.

12.2.6 KARMA is not responsible for the transportation costs for repair and replacement.

12.2.7 Warranty maintenance is the repair or replacement according to the condition of the parts, and replaced parts will be the property of KARMA.

12.2.8 KARMA reserves the right to modify product specifications without further notice; KARMA is not responsible for any changes to product specifications.

12.3 The Claims from This Warranty Shall Not Arise for The Following Reasons

12.3.1 The product or part has been damaged by accident, improper use, incorrect assembly or poor maintenance. The evaluation of it is the privilege of KARMA.

12.3.2 Damage resulting from normal wear and tear.

12.3.3 Any overloading of the product, please check the label for maximum user weight.

12.3.4 The product or part has not been maintained or serviced in accordance with the manufacturer's recommendations as shown in the User Manuals and/or the Service

Manuals.

12.3.5 Use or install parts or accessories which are not manufactured or not approved by KARMA.

12.3.6 Damage resulting from use in unsuitable environments.

12.3.7 Damage resulting from any addition, modification, or alteration of the product or parts without the approval by KARMA.

12.3.8 Damage resulting from external factors, such as chemicals, oil, debris, etc.

12.3.9 Damage caused by natural disasters.

12.4 The Responsibilities of the User

12.4.1 Fully adhere to operation guidelines set forth in this manual.

12.4.2 Perform self-inspection and basic maintenance.

12.4.3 Keep a record of self-inspections and basic maintenance.

12.4.4 Not permit any alteration, addition, or modification or use of parts not manufactured by KARMA.

12.4.5 Thoroughly read and understand this manual.

12.5 The Responsibilities of the Dealer

12.5.1 Follow this owner's manual and educate user about product operation and basic maintenance

12.5.2 Verify and check whether the warranty conditions are met.

12.5.3 Provide relevant warranty information and recommendations for improvements.

12.6 Transfer of Warranty Rights

If you purchase a second-hand KARMA wheelchair while it is still within the warranty period, bring this user manual and the wheelchair to the authorized dealer and perform necessary product inspection, maintenance and warranty inheritance procedure.

Full Name:	
Gender:	
Date of Birth:	
Address:	
Model:	
Serial Number:	
Date of Purchase:	
Purchaser Signature:	

Dealer's Data

Name of the Store:	
Phone No. and Address:	

karma

A Better Wheelchair, A Better Fit



KARMA MOBILITY S.L European Support Center.
www.karmamobility.es
+34 984 390 907
karma@karmamobility.es

KARMA MOBILITY LTD. UK representative
www.karmamobility.co.uk
+44 845 630 3436
info@karmamobility.co.uk

KARMA MEDICAL PRODUCTS CO., LTD.
www.KarmaMedical.com
+886 5 206 6688
globalsales@karmam.com.tw